

Technical Information

Proline Prosonic Flow W 400

Ultrasonic transit time flowmeter



Clamp-on meter with Heartbeat Technology and web server for the water and wastewater industry

Application

- The measuring principle is non-invasive and independent of pressure, density and conductivity
- Bidirectional measurement for water and wastewater as well as process water and hydropower plants

Device properties

- Mounting without process interruption
- Wide nominal diameter range: DN 15 to 4000 (½ to 160")
- Medium temperature up to +130 °C (+266 °F)
- Transmitter housing made of durable polycarbonate or aluminium
- Remote version for wall mounting
- Integrated data logger: measured values monitoring

Your benefits

- Short inlet run thanks to FlowDC
- Low capital investment – cost-effectiveness increases with pipe diameter (up to DN 4000/160")
- Long-term stable signal – maintenance-free permanent mounting from outside with coupling pads
- Reliable measurement on various pipe materials – sensor for GRP and plastic pipes available
- Safe operation – no need to open the device due to display with touch control, background lighting
- Full remote access – web server
- Integrated diagnostics, verification and monitoring – Heartbeat Technology





Table of contents

Document information	3	Process	39
Symbols	3	Medium temperature range	39
Function and system design	4	Sound velocity range	39
Measuring principle	4	Medium pressure range	39
Measuring system	5	Pressure loss	39
Equipment architecture	11	Mechanical construction	40
Security	11	Dimensions in SI units	40
Input	13	Dimensions in US units	44
Measured variable	13	Weight	47
Measuring range	13	Materials	47
Operable flow range	13	Operability	48
Input signal	13	Operating concept	48
Output	14	Languages	49
Output signal	14	Local operation	49
Signal on alarm	15	Remote operation	50
Low flow cut off	16	Service interface	50
Galvanic isolation	16	Supported operating tools	51
Protocol-specific data	16	HistoROM data management	52
Power supply	17	Certificates and approvals	53
Terminal assignment	17	CE mark	54
Supply voltage	17	UKCA marking	54
Power consumption	18	RCM mark	54
Current consumption	18	Ex approval	54
Power supply failure	18	HART certification	54
Electrical connection	18	Radio approval	54
Potential equalization	20	Other standards and guidelines	54
Terminals	20	Ordering information	55
Cable entries	20	Application packages	55
Cable specification	20	Diagnostics functions	55
Performance characteristics	21	Heartbeat Technology	56
Reference operating conditions	21	FlowDC	56
Maximum measured error	21	Accessories	56
Repeatability	23	Device-specific accessories	56
Influence of ambient temperature	23	Communication-specific accessories	57
Mounting	23	Service-specific accessories	58
Mounting location	23	System components	59
Orientation	24	Documentation	59
Inlet and outlet runs	24	Standard documentation	59
Mounting the sensor	25	Supplementary device-dependent documentation	60
Mounting the transmitter housing	37	Registered trademarks	60
Special mounting instructions	38		
Environment	38		
Ambient temperature range	38		
Storage temperature	38		
Degree of protection	39		
Vibration- and shock-resistance	39		
Electromagnetic compatibility (EMC)	39		





Document information

Symbols









Electrical symbols

Symbol	Meaning
	Direct current
	Alternating current
	Direct current and alternating current
	Ground connection A grounded terminal which, as far as the operator is concerned, is grounded via a grounding system.
	Protective Earth (PE) A terminal which must be connected to ground prior to establishing any other connections. The ground terminals are situated inside and outside the device: <ul style="list-style-type: none"> ▪ Inner ground terminal: Connects the protective earth to the mains supply. ▪ Outer ground terminal: Connects the device to the plant grounding system.



Communication-specific symbols

Symbol	Meaning
	Wireless Local Area Network (WLAN) Communication via a wireless, local network.
	Bluetooth Wireless data transmission between devices over a short distance.
	LED Light emitting diode is off.
	LED Light emitting diode is on.
	LED Light emitting diode is flashing.

Symbols for certain types of information

Symbol	Meaning
	Permitted Procedures, processes or actions that are permitted.
	Preferred Procedures, processes or actions that are preferred.
	Forbidden Procedures, processes or actions that are forbidden.
	Tip Indicates additional information.
	Reference to documentation
	Reference to page
	Reference to graphic
	Visual inspection

Symbols in graphics

Symbol	Meaning
1, 2, 3, ...	Item numbers
1., 2., 3., ...	Series of steps
A, B, C, ...	Views
A-A, B-B, C-C, ...	Sections
	Hazardous area
	Safe area (non-hazardous area)
	Flow direction

Function and system design

Measuring principle

The measuring system uses a measurement method based on the transit time difference. In this measurement method, acoustic signals (ultrasonic) are transmitted between two sensors. Signal transmission is bidirectional, i.e. the sensor operates as both a sound transmitter and a sound receiver.

As the speed of propagation of the sound waves is slower against the flow direction than in the flow direction, this results in a transit time difference. This transit time difference is directly proportional to the flow velocity.

The measuring system calculates the volume flow of the medium from the measured transit time difference and the pipe cross-sectional area. The sound velocity of the medium is simultaneously measured along with the transit time difference. With this additional measured variable, it is possible to differentiate between different media or monitor the medium quality.

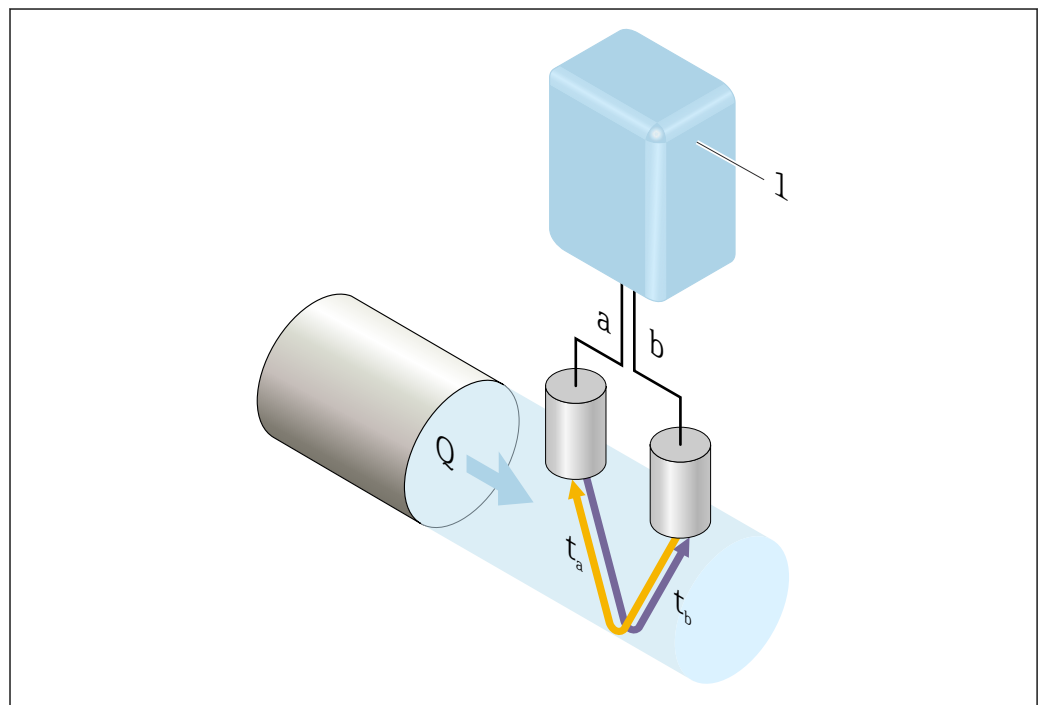

- 1 Transmitter
a Sensor
b Sensor
Q Volume flow
 Δt Transit time difference $\Delta t = t_a - t_b$; flow velocity $v \sim \Delta t$

Measuring system

The measuring system consists of a transmitter and one or two sensor sets. The transmitter and sensor sets are mounted in physically separate locations. They are interconnected by sensor cables.

The measuring system uses a measurement method based on the transit time difference. Here, the sensors work as sound generators and sound receivers. Depending on the application and version, the sensors can be arranged for a measurement via 1, 2, 3 or 4 traverses → 6.

The transmitter serves to control the sensor sets, to prepare, process and evaluate the measuring signals, and to convert the signals to the desired output variable.

Transmitter

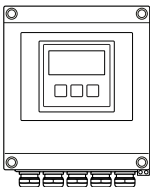
<p>Proline 400</p>  <p style="text-align: right; font-size: small;">A0045222</p>	<p>Device versions and materials: Remote version: wall-mount housing</p> <ul style="list-style-type: none"> ■ Polycarbonate plastic ■ Aluminum, AlSi10Mg, coated <p>Configuration:</p> <ul style="list-style-type: none"> ■ External operation via four-line, illuminated local display with touch control and guided menus ("Make-it-run" wizards) for applications ■ Via operating tools (e.g. FieldCare) ■ Via Web browser (e.g. Microsoft Internet Explorer)
--	--

Sensor cables

Sensor cables can be ordered in different lengths → 56

- Length: max. 30 m (90 ft)
- Cable with a common shield and individual shielded cores

Sensor

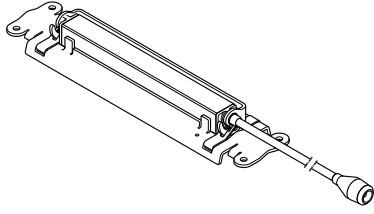
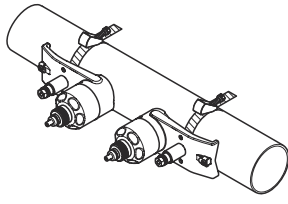
<p>Prosonic Flow W DN 15 to 65 (½ to 2½")</p>  <p style="text-align: right; font-size: small;">A0011484</p>	<ul style="list-style-type: none"> ■ Measurement of: <ul style="list-style-type: none"> ■ Pure liquids or slightly contaminated liquids ■ Water, e.g. drinking water, industrial water, saltwater, de-ionized water and cooling and heating water ■ Nominal diameter range: DN 15 to 4000 (½ to 160") ■ Materials: <ul style="list-style-type: none"> ■ Sensor holder: Stainless steel 1.4404 (316L) ■ Sensor housing: Stainless steel 1.4404 (316L) ■ Strapping band/bracket: Stainless steel 1.4404 (316L) ■ Sensor contact surface: Chemically stable plastic
<p>DN 50 to 4000 (2 to 160")</p>  <p style="text-align: right; font-size: small;">A0013475</p> <p>1 Example: 1 sensor set with 2 traverses</p>	

Accessories for mounting

The necessary distances must be determined for the sensors. Information about the medium, the pipe material used and the exact pipe dimensions is required to determine these values. The values for the sound velocity of the following media, pipe materials and liner materials are saved in the transmitter:

Medium		Pipe material		Liner
<ul style="list-style-type: none"> ■ Water ■ Seawater ■ Distilled water ■ Ammonia NH₃ ■ Benzene 	<ul style="list-style-type: none"> ■ Ethanol ■ Glycol ■ Milk ■ Methanol ■ User-specific liquid 	<ul style="list-style-type: none"> ■ Carbon steel ■ Graphite cast iron ■ Stainless steel ■ 1.4301 (UNS S30400) ■ 1.4401 (UNS S31600) ■ 1.4550 (UNS S34700) ■ Hastelloy C ■ PVC ■ PE ■ LDPE 	<ul style="list-style-type: none"> ■ HDPE ■ GFR ■ PVDF ■ PA ■ PP ■ PTFE ■ Pyrex glass ■ Asbestos cement ■ Copper ■ Unknown pipe material 	<ul style="list-style-type: none"> ■ None ■ Cement ■ Rubber ■ Epoxy resin ■ Unknown liner material

Sensor set selection and arrangement

 If mounting horizontally, always mount the sensor set so that it is offset at an angle of at least ±30° to the top of the measuring pipe to avoid incorrect measurements caused by empty space at the top of the pipe.

The sensors can be arranged in different ways:

- Mounting arrangement for measurement with 1 sensor set (1 measuring path):
 - The sensors are located on opposite sides of the pipe (offset by 180°): measurement with 1 or 3 traverses
 - The sensors are located on the same side of the pipe: measurement with 2 or 4 traverses
 - Mounting arrangement for measurement with 2 sensor sets (2 measuring paths):
 - 1 sensor of each sensor set is located on the opposite side of the pipe (offset by 180°): measurement with 1 or 3 traverses
 - The sensors are located on the same side of the pipe: measurement with 2 or 4 traverses
- The sensor sets are arranged on the pipe, offset by 90°.

i Using 5 MHz sensors

Here, the rails of the two sensor sets are always arranged at an angle of 180° to one another and connected by cables for all measurements with 1, 2, 3 or 4 traverses. The sensor functions are assigned in the two rails via the transmitter electronics unit depending on the selected number of traverses. It is not necessary to swap the cables in the transmitter between the channels.

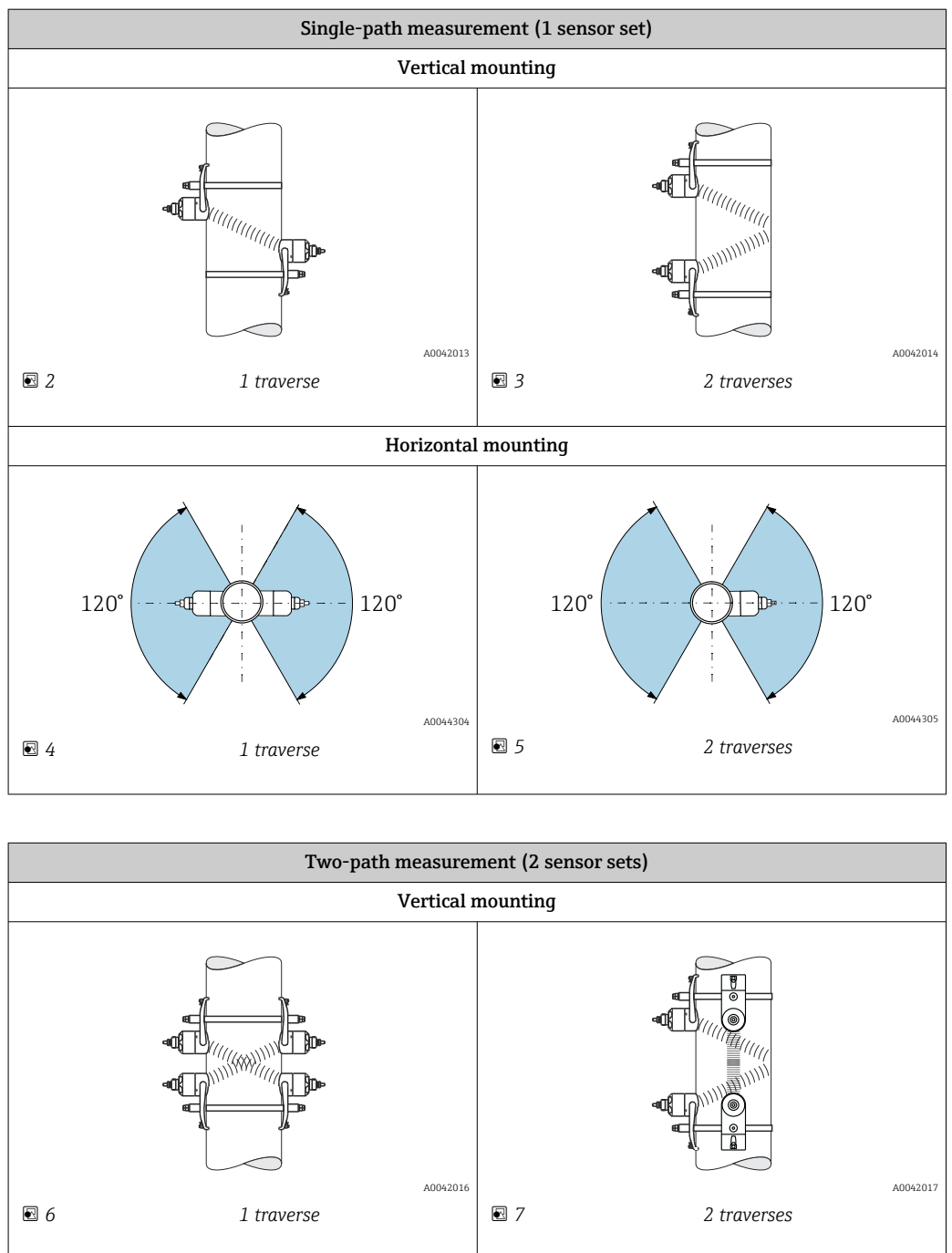

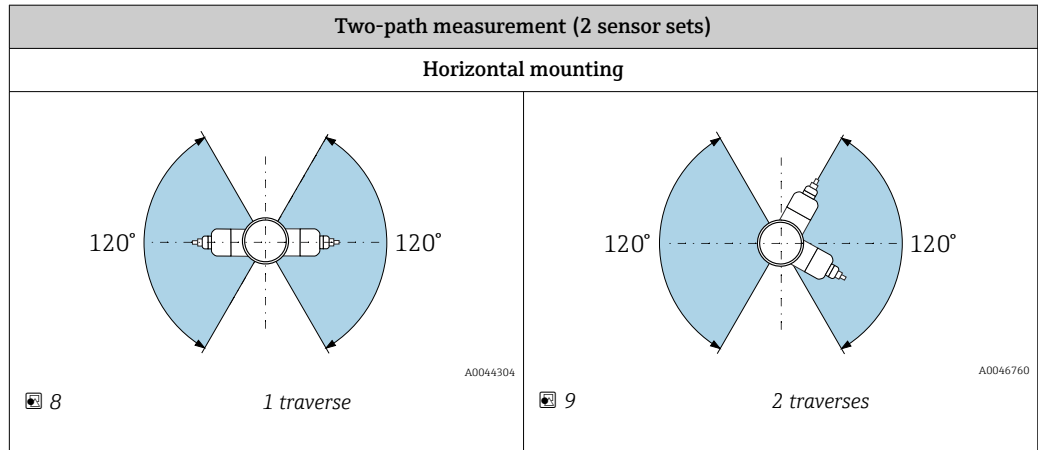

Operating frequency selection

The sensors of the measuring device are available with adapted operating frequencies. These frequencies are optimized for different properties of measuring pipes (material, pipe wall thickness) and media (kinematic viscosity) for the resonance behavior of the measuring pipes. If these properties are known, an optimum selection can be made according to the following tables ¹⁾. If these properties are not (completely) known, the sensors can be assigned as follows:

- 5 MHz for DN 15 to 65 (½ to 2½")
- 2 MHz for DN 50 to 300 (2 to 12")
- 1 MHz for DN 100 to 4000 (4 to 160")
- 0.5 MHz for DN 150 to 4000 (6 to 160")
- 0.3 MHz for DN 1000 to 4000 (40 to 160")

Measuring pipe material	Measuring pipe nominal diameter	Recommendation
Steel, cast iron	< DN 65 (2½")	C-500-A
	≥ DN 65 (2½")	See table "Measuring pipe material: steel, cast iron" → 8
Plastic	< DN 50 (2")	C-500-A
	≥ DN 50 (2")	See table "Measuring pipe material: plastic" → 9
Glass-fiber reinforced plastic	< DN 50 (2")	C-500-A (with restrictions)
	≥ DN 50 (2")	See table "Measuring pipe material: glass-fiber reinforced plastic" → 9

Measuring pipe material: steel, cast iron

Pipe wall thickness [mm (in)]	Kinematic viscosity cSt [mm²/s]		
	0 < ν ≤ 10	10 < ν ≤ 100	100 < ν ≤ 1000
	Transducer frequency (sensor version / number of traverses) ¹⁾		
1.0 to 1.9 (0.04 to 0.07)	2 MHz (C-200 / 2)	2 MHz (C-200 / 1)	2 MHz (C-200 / 1)
1.9 to 2.2 (0.07 to 0.09)	1 MHz (C-100 / 2)	1 MHz (C-100 / 1)	1 MHz (C-100 / 1)
2.2 to 2.8 (0.09 to 0.11)	2 MHz (C-200 / 2)	1 MHz (C-100 / 2)	1 MHz (C-100 / 1)
2.8 to 3.4 (0.11 to 0.13)	1 MHz (C-100 / 2)	1 MHz (C-100 / 1)	1 MHz (C-100 / 1)
3.4 to 4.2 (0.13 to 0.17)	2 MHz (C-200 / 2)	2 MHz (C-200 / 1)	1 MHz (C-100 / 1)
4.2 to 5.9 (0.17 to 0.23)	1 MHz (C-100 / 2)	1 MHz (C-100 / 1)	0.5 MHz (C-050 / 2)

1) Recommendation: product design and sizing in Applicator → 58

Pipe wall thickness [mm (in)]	Kinematic viscosity cSt [mm ² /s]		
	0 < ν ≤ 10	10 < ν ≤ 100	100 < ν ≤ 1000
	Transducer frequency (sensor version / number of traverses) ¹⁾		
5.9 to 10.0 (0.23 to 0.39)	2 MHz (C-200 / 2)	1 MHz (C-100 / 2)	0.5 MHz (C-050 / 2)
>10.0 (0.39)	1 MHz (C-100 / 2)	1 MHz (C-100 / 1)	0.5 MHz (C-050 / 1)

1) The table shows a typical selection. In critical situations, the optimum sensor type may differ from these recommendations.

Measuring pipe material: plastic

Nominal diameter [mm (")]	Kinematic viscosity cSt [mm ² /s]		
	0 < ν ≤ 10	10 < ν ≤ 100	100 < ν ≤ 1000
	Transducer frequency (sensor version / number of traverses) ¹⁾		
15 to 50 (½ to 2)	5 MHz (C-500 / 2)	5 MHz (C-500 / 2)	5 MHz (C-500 / 2)
50 to 80 (2 to 3)	2 MHz (C-200 / 2)	1 MHz (C-100 / 2)	0.5 MHz (C-050 / 2)
80 to 150 (3 to 6)	1 MHz (C-100 / 2)	1 MHz (C-100 / 2)	0.5 MHz (C-050 / 2)
150 to 200 (6 to 8)	1 MHz (C-100 / 2)	0.5 MHz (C-050 / 2)	0.5 MHz (C-050 / 2)
200 to 300 (8 to 12)	1 MHz (C-100 / 2)	0.5 MHz (C-050 / 2)	0.5 MHz (C-050 / 2)
300 to 400 (12 to 16)	1 MHz (C-100 / 1)	0.5 MHz (C-050 / 2)	0.5 MHz (C-050 / 1)
400 to 500 (16 to 20)	1 MHz (C-100 / 1)	0.5 MHz (C-050 / 1)	0.5 MHz (C-050 / 1)
500 to 1000 (20 to 40)	0.5 MHz (C-050 / 1)	0.5 MHz (C-050 / 1)	-
1000 to 4000 (40 to 160)	0.3 MHz (C-030 / 1)	-	-

1) The table shows a typical selection. In critical situations, the optimum sensor type may differ from these recommendations.

Measuring pipe material: glass-fiber reinforced plastic

Nominal diameter [mm (")]	Kinematic viscosity cSt [mm ² /s]		
	0 < ν ≤ 10	10 < ν ≤ 100	100 < ν ≤ 1000
	Transducer frequency (sensor version / number of traverses) ¹⁾		
15 to 50 (½ to 2)	5 MHz (C-500 / 2)	5 MHz (C-500 / 2)	5 MHz (C-500 / 2)
50 to 80 (2 to 3)	1 MHz (C-100 / 2)	0.5 MHz (C-050 / 2)	0.5 MHz (C-050 / 1)
80 to 150 (3 to 6)	1 MHz (C-100 / 2)	0.5 MHz (C-050 / 1)	0.5 MHz (C-050 / 1)
150 to 200 (6 to 8)	0.5 MHz (C-050 / 2)	0.5 MHz (C-050 / 1)	-
200 to 300 (8 to 12)	0.5 MHz (C-050 / 2)	0.5 MHz (C-050 / 1)	-
300 to 400 (12 to 16)	0.5 MHz (C-050 / 2)	0.5 MHz (C-050 / 1)	-
400 to 500 (16 to 20)	0.5 MHz (C-050 / 1)	-	-
500 to 1000 (20 to 40)	0.5 MHz (C-050 / 1)	-	-
1000 to 4000 (40 to 160)	0.3 MHz (C-030 / 1)	-	-

1) The table shows a typical selection. In critical situations, the optimum sensor type may differ from these recommendations.



- If clamp-on sensors are used, a 2 traverse-type installation is recommended. This is the easiest and most convenient type of installation, particularly for measuring devices whose pipe can only be accessed with difficulty from one side.
- A 1 traverse installation is recommended for the following installation conditions:
 - Certain plastic pipes with a wall thickness >4 mm (0.16 in)
 - Pipes made of composite materials (e.g. glass-fiber reinforced plastic)
 - Lined pipes
 - Applications with media with high acoustic damping

Operation

Single-path measurement

In the case of single-path measurement, the flow is measured at the measuring point without the option of compensation.

For this it is necessary to adhere strictly to the specified inlet and outlet runs after disturbances in the measuring pipe (e.g. elbows, extensions, reductions).

 To ensure the best possible measurement performance and measuring accuracy, the configuration with two sensor sets ²⁾ with FlowDC ³⁾ is recommended.

Two-path measurement

In the case of two-path measurement, the flow is measured by two measurements (two measuring paths/sensor sets) at the measuring point.

The two sensor sets are mounted at one measuring point with one or two traverses for this purpose. It is generally possible to arrange the sensors on one or two different measurement planes. If the sensors are installed with two measurement planes, a minimum sensor plane rotation of 30° in relation to the pipe axis must be observed.

The average of the measured values of both sensor sets is calculated. The configuration of the measurement is only performed once and is adopted for both measuring paths.

 When extending the measuring point from single-path measurement to two-path measurement, an identical sensor must be selected.

Two-path measurement with FlowDC ⁴⁾

In the case of two-path measurement with FlowDC, the flow is measured by two measurements at the measuring point.

For this, the two sensor sets are installed on the measuring pipe, offset at a specific angle to one another (180° for 1 traverse, 90° for 2 traverses). This is independent of the rotation position of the two sensor sets on the measuring pipe.

The measured values of both sensor sets are averaged. Based on this average measurement value, the measured value is compensated depending on the type of disturbance and the distance from the measuring point to the disturbance point. This makes it possible to maintain the specified accuracy and repeatability for measurements in non-ideal conditions (e.g. short inlet runs), with inlet runs up to only 2x DN before and after the measuring point.

The configuration of the two measuring paths is only performed once and is adopted for both measuring paths.

2) Order code for "Mounting type", option A2 "Clamp-on, 2-channel, 2-sensor sets"

3) Order code for "Application package", option EN "FlowDC"

4) Flow disturbance compensation

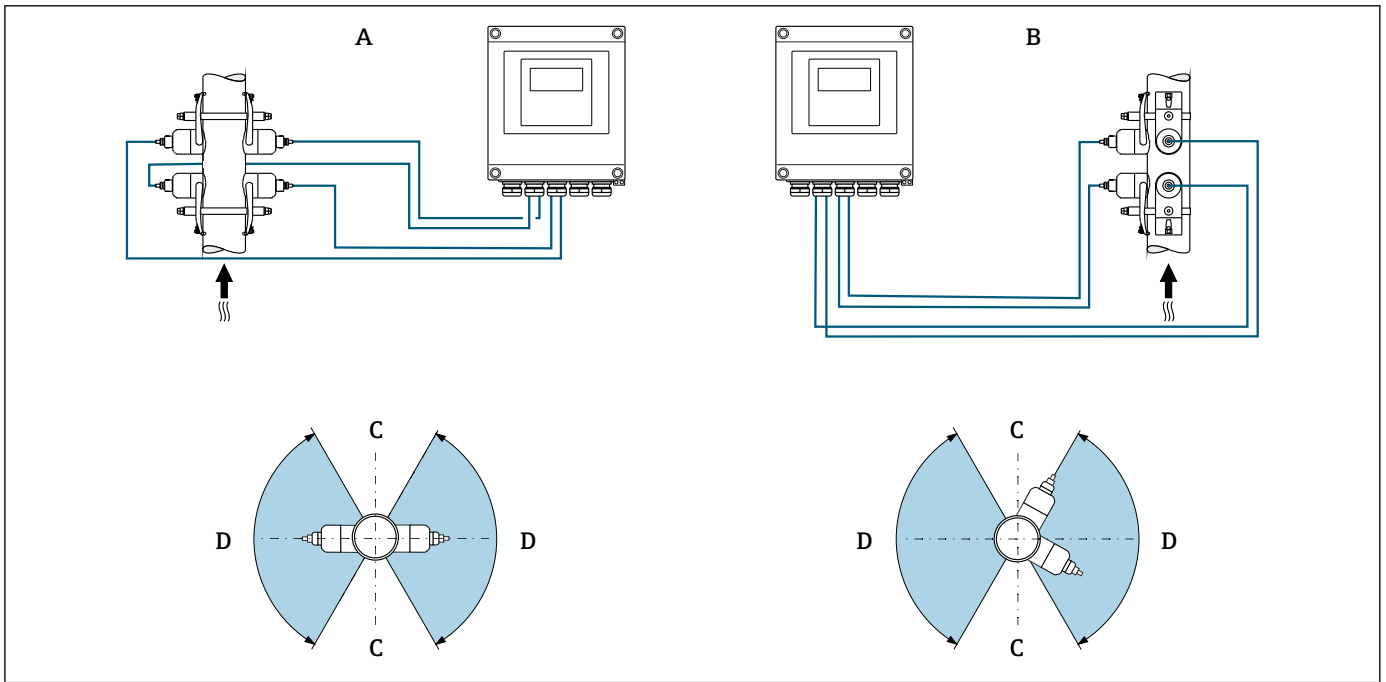

A0044944

10 Two-path measurement: examples for the horizontal arrangement of the sensor sets at a measuring point

- A Installation of the sensor sets for measurement via 1 traverse
- B Installation of the sensor sets for measurement via 2 traverses
- C Non-recommended installation range with horizontal orientation (60°)
- D Recommended installation range max. 120°

i If FlowDC is not used, it is necessary to adhere strictly to the specified inlet and outlet runs after disturbances in the measuring pipe (e.g. elbows, extensions, reductions) to obtain correct flow measured values.

Equipment architecture

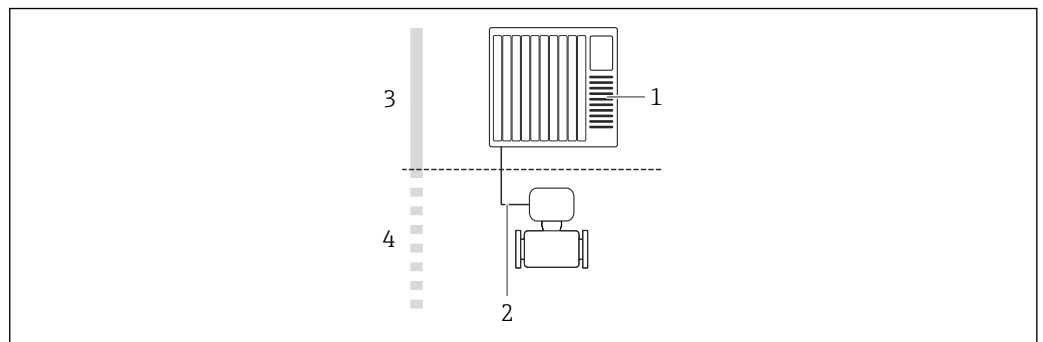

A0044936

11 Possibilities for integrating measuring devices into a system

- 1 Control system (e.g. PLC)
- 2 4 to 20 mA HART, pulse/frequency/switch output
- 3 Non-hazardous area
- 4 Non-hazardous area and Zone 2/Div. 2

Security



IT security

Our warranty is valid only if the device is installed and used as described in the Operating Instructions. The device is equipped with security mechanisms to protect it against any inadvertent changes to the settings.

IT security measures, which provide additional protection for the device and associated data transfer, must be implemented by the operators themselves in line with their security standards.

Device-specific IT security

The device offers a range of specific functions to support protective measures on the operator's side. These functions can be configured by the user and guarantee greater in-operation safety if used correctly. An overview of the most important functions is provided in the following section:

Function/interface	Factory setting	Recommendation
Write protection via hardware write protection switch	Not enabled	On an individual basis following risk assessment
Access code (also applies for Web server login or FieldCare connection) →  12	Not enabled (0000)	Assign a customized access code during commissioning
WLAN (order option in display module)	Enabled	On an individual basis following risk assessment
WLAN security mode	Enabled (WPA2-PSK)	Do not change
WLAN passphrase (password) →  12	Serial number	Assign a customized WLAN passphrase during commissioning
WLAN mode	Access point	On an individual basis following risk assessment
Web server →  12	Enabled	On an individual basis following risk assessment
CDI-RJ45 service interface	–	On an individual basis following risk assessment

Protecting access via a password

Different passwords are available to protect write access to the device parameters or access to the device via the WLAN interface.

- **User-specific access code**
Protect write access to the device parameters via the local display, Web browser or operating tool (e.g. FieldCare, DeviceCare). Access authorization is clearly regulated through the use of a user-specific access code.
- **WLAN passphrase**
The network key protects a connection between an operating unit (e.g. notebook or tablet) and the device via the WLAN interface which can be ordered as an option.

User-specific access code

Write access to the device parameters via the local display or operating tool (e.g. FieldCare, DeviceCare) can be protected by the modifiable, user-specific access code.

WLAN passphrase: Operation as WLAN access point

A connection between an operating unit (e.g. notebook or tablet) and the device via the WLAN interface, which can be ordered as an optional extra, is protected by the network key. The WLAN authentication of the network key complies with the IEEE 802.11 standard.

When the device is delivered, the network key is pre-defined depending on the device. It can be changed via the **WLAN settings** submenu in the **WLAN passphrase** parameter.

General notes on the use of passwords

- The access code and network key supplied with the device should be changed during commissioning.
- Follow the general rules for generating a secure password when defining and managing the access code or network key.
- The user is responsible for the management and careful handling of the access code and network key.

Access via Web server

The device can be operated and configured via a Web browser with the integrated Web server. The connection is via the service interface (CDI-RJ45) or the WLAN interface.

The Web server is enabled when the device is delivered. The Web server can be disabled if necessary (e.g. after commissioning) via the **Web server functionality** parameter.

The device and status information can be hidden on the login page. This prevents unauthorized access to the information.



For detailed information on device parameters, see:
The "Description of Device Parameters" document

Input

Measured variable	<p>Direct measured variables</p> <ul style="list-style-type: none"> ▪ Volume flow ▪ Flow velocity ▪ Sound velocity <p>Calculated measured variables</p> <p>Mass flow</p>								
Measuring range	<p>$v = 0$ to 15 m/s (0 to 50 ft/s)</p> <p> Measuring range depending on the sensor version.</p> <p> To calculate the measuring range, use the <i>Applicator</i> sizing tool → 58</p>								
Operable flow range	<p>Over 150 : 1</p>								
Input signal	<p>External measured values</p> <p>Interfaces that allow externally measured variables (temperature, density) to be transmitted to the measuring device are optionally available for the device.</p> <p><i>HART protocol</i></p> <p>The measured values are written from the automation system to the measuring device via the HART protocol. The temperature and density measuring device must support the following protocol-specific functions:</p> <ul style="list-style-type: none"> ▪ HART protocol ▪ Burst mode <p>Status input</p> <table border="1" data-bbox="497 1447 1533 1749"> <tr> <td data-bbox="497 1447 778 1518">Maximum input values</td> <td data-bbox="778 1447 1533 1518"> <ul style="list-style-type: none"> ▪ DC 30 V ▪ 6 mA </td> </tr> <tr> <td data-bbox="497 1518 778 1563">Response time</td> <td data-bbox="778 1518 1533 1563"> <p>Configurable: 5 to 200 ms</p> </td> </tr> <tr> <td data-bbox="497 1563 778 1630">Input signal level</td> <td data-bbox="778 1563 1533 1630"> <ul style="list-style-type: none"> ▪ Low signal (low): DC -3 to +5 V ▪ High signal (high): DC 12 to 30 V </td> </tr> <tr> <td data-bbox="497 1630 778 1749">Assignable functions</td> <td data-bbox="778 1630 1533 1749"> <ul style="list-style-type: none"> ▪ Off ▪ Reset totalizers 1-3 separately ▪ Reset all totalizers ▪ Flow override </td> </tr> </table>	Maximum input values	<ul style="list-style-type: none"> ▪ DC 30 V ▪ 6 mA 	Response time	<p>Configurable: 5 to 200 ms</p>	Input signal level	<ul style="list-style-type: none"> ▪ Low signal (low): DC -3 to +5 V ▪ High signal (high): DC 12 to 30 V 	Assignable functions	<ul style="list-style-type: none"> ▪ Off ▪ Reset totalizers 1-3 separately ▪ Reset all totalizers ▪ Flow override
Maximum input values	<ul style="list-style-type: none"> ▪ DC 30 V ▪ 6 mA 								
Response time	<p>Configurable: 5 to 200 ms</p>								
Input signal level	<ul style="list-style-type: none"> ▪ Low signal (low): DC -3 to +5 V ▪ High signal (high): DC 12 to 30 V 								
Assignable functions	<ul style="list-style-type: none"> ▪ Off ▪ Reset totalizers 1-3 separately ▪ Reset all totalizers ▪ Flow override 								

Output

Output signal

Current output

Current output	Can be set as: <ul style="list-style-type: none"> 4 to 20 mA NAMUR 4 to 20 mA US 4 to 20 mA HART 0 to 20 mA
Maximum output values	<ul style="list-style-type: none"> DC 24 V (no flow) 22.5 mA
Load	250 to 700 Ω
Resolution	0.38 μ A
Damping	Adjustable: 0 to 999.9 s
Assignable measured variables	<ul style="list-style-type: none"> Volume flow Mass flow Sound velocity Flow velocity Electronic temperature <p> The range of options increases if the measuring device has one or more application packages.</p>

Pulse/frequency/switch output

Function	<ul style="list-style-type: none"> With the order code for "Output; Input", option H: output 2 can be set as a pulse or frequency output With the order code for "Output; Input", option I: output 2 and 3 can be set as a pulse, frequency or switch output
Version	Passive, open collector
Maximum input values	<ul style="list-style-type: none"> DC 30 V 250 mA
Voltage drop	At 25 mA: \leq DC 2 V
Pulse output	
Pulse width	Adjustable: 0.05 to 2 000 ms
Maximum pulse rate	10 000 Impulse/s
Pulse value	Adjustable
Assignable measured variables	<ul style="list-style-type: none"> Volume flow Mass flow
Frequency output	
Output frequency	Adjustable: 0 to 12 500 Hz
Damping	Adjustable: 0 to 999 s
Pulse/pause ratio	1:1
Assignable measured variables	<ul style="list-style-type: none"> Volume flow Mass flow Sound velocity Flow velocity Electronic temperature
Switch output	
Switching behavior	Binary, conductive or non-conductive
Switching delay	Adjustable: 0 to 100 s

Number of switching cycles	Unlimited
Assignable functions	<ul style="list-style-type: none"> ▪ Off ▪ On ▪ Diagnostic behavior ▪ Limit value <ul style="list-style-type: none"> ▪ Volume flow ▪ Mass flow ▪ Sound velocity ▪ Flow velocity ▪ Totalizer 1-3 ▪ Electronic temperature ▪ Flow direction monitoring ▪ Status <ul style="list-style-type: none"> Low flow cut off

Signal on alarm

Depending on the interface, failure information is displayed as follows:

Current output 4 to 20 mA

4 to 20 mA

Failure mode	Choose from: <ul style="list-style-type: none"> ▪ 4 to 20 mA in accordance with NAMUR recommendation NE 43 ▪ 4 to 20 mA in accordance with US ▪ Min. value: 3.59 mA ▪ Max. value: 22.5 mA ▪ Freely definable value between: 3.59 to 22.5 mA ▪ Actual value ▪ Last valid value
---------------------	--

0 to 20 mA

Failure mode	Choose from: <ul style="list-style-type: none"> ▪ Maximum alarm: 22 mA ▪ Freely definable value between: 0 to 22.5 mA
---------------------	---

HART current output

Device diagnostics	Device condition can be read out via HART Command 48
---------------------------	--

Pulse/frequency/switch output

Pulse output	
Failure mode	Choose from: <ul style="list-style-type: none"> ▪ Actual value ▪ No pulses
Frequency output	
Failure mode	Choose from: <ul style="list-style-type: none"> ▪ Actual value ▪ 0 Hz ▪ Defined value: 0 to 12 500 Hz
Switch output	
Failure mode	Choose from: <ul style="list-style-type: none"> ▪ Current status ▪ Open ▪ Closed

Local display

Plain text display	With information on cause and remedial measures
Backlight	Red backlighting indicates a device error.

 Status signal as per NAMUR recommendation NE 107

Interface/protocol

- Via digital communication:
 - HART protocol
- Via service interface
 - CDI-RJ45 service interface
 - WLAN interface

Plain text display	With information on cause and remedial measures
---------------------------	---

 Additional information on remote operation →  50

Web browser

Plain text display	With information on cause and remedial measures
---------------------------	---

Light emitting diodes (LED)

Status information	Status indicated by various light emitting diodes The following information is displayed depending on the device version: <ul style="list-style-type: none"> ▪ Supply voltage active ▪ Data transmission active ▪ Device alarm/error has occurred
---------------------------	---

Low flow cut off

The switch points for low flow cut off are user-selectable.

Galvanic isolation

The following connections are galvanically isolated from each other:

- Inputs
- Outputs
- Power supply

The clamp-on sensors can also be mounted on cathodically protected pipes⁵⁾. Solution available on request.

Protocol-specific data**HART**

Manufacturer ID	0x11
Device type ID	0x1169
HART protocol revision	7
Device description files (DTM, DD)	Information and files under: www.endress.com
HART load	Min. 250 Ω
Dynamic variables PV, SV, TV, QV	<ul style="list-style-type: none"> ▪ Read out the dynamic variables via HART command 3 ▪ The measured variables can be freely assigned to the dynamic variables

5) Only DN 50 to 4000 (2 to 160") and non-Ex

Device variables	<ul style="list-style-type: none"> ▪ Read out the device variables via HART command 9 ▪ The measured variables can be freely assigned ▪ A maximum of 8 device variables can be transmitted
System integration	Operating Instructions for the device

Power supply

Terminal assignment

Transmitter: 0 to 20 mA/4 to 20 mA HART

The sensor can be ordered with terminals.

Connection methods available		Possible options for order code "Electrical connection"
Outputs	Power supply	
Terminals	Terminals	<ul style="list-style-type: none"> ▪ Option A: coupling M20x1.5 ▪ Option B: thread M20x1.5 ▪ Option C: thread G ½" ▪ Option D: thread NPT ½"

Supply voltage

Order code "Power supply"	Terminal numbers	terminal voltage		Frequency range
Option L (wide range power unit)	1 (L+/L), 2 (L-/N)	DC 24 V	±25%	–
		AC 24 V	±25%	50/60 Hz, ±4 Hz
		AC 100 to 240 V	-15 to +10%	50/60 Hz, ±4 Hz

Signal transmission for current output 0 to 20 mA/4 to 20 mA HART and other outputs and inputs

Order code for "Output" and "Input"	Terminal numbers							
	Output 1		Output 2		Output 3		Input	
	26 (+)	27 (-)	24 (+)	25 (-)	22 (+)	23 (-)	20 (+)	21 (-)
Option H	Current output ▪ 4 to 20 mA HART (active) ▪ 0 to 20 mA (active)		Pulse/frequency output (passive)		Switch output (passive)		–	
Option I	Current output ▪ 4 to 20 mA HART (active) ▪ 0 to 20 mA (active)		Pulse/frequency/switch output (passive)		Pulse/frequency/switch output (passive)		Status input	

Supply voltage

Transmitter

Order code for "Power supply"	terminal voltage		Frequency range
Option L	DC 24 V	±25%	–
	AC 24 V	±25%	50/60 Hz, ±4 Hz
	AC 100 to 240 V	-15 to +10%	50/60 Hz, ±4 Hz

Power consumption	Order code for "Output"	Maximum power consumption
	Option H: 4-20mA HART, pulse/frequency output, switch output	30 VA/8 W
	Option I: 4-20mA HART, 2 x pulse/frequency/switch output, status input	30 VA/8 W

Current consumption

Transmitter

Order code for "Power supply"	Maximum Current consumption	Maximum switch-on current
Option L: AC 100 to 240 V	145 mA	25 A (< 5 ms)
Option L: AC/DC 24 V	350 mA	27 A (< 5 ms)

Power supply failure

- Totalizers stop at the last value measured.
- Depending on the device version, the configuration is retained in the device memory or in the pluggable data memory (HistoROM DAT).
- Error messages (incl. total operated hours) are stored.

Electrical connection

Connecting the transmitter

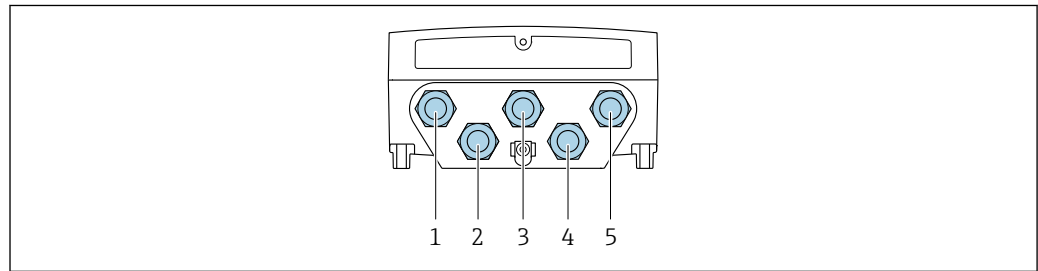

A0044948

12 Wall-mount housing, remote version: connection of supply voltage and signal transmission

- 1 Cable entry for supply voltage
- 2 Cable entry for sensor cable
- 3 Cable entry for sensor cable
- 4 Cable entry for signal transmission
- 5 Cable entry for signal transmission

Connection examples

Current output 4 to 20 mA HART

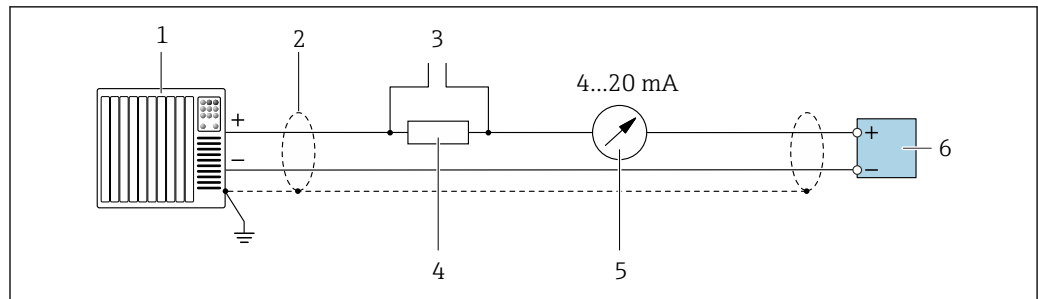

A0029055

13 Connection example for 4 to 20 mA HART current output (active)

- 1 Automation system with current input (e.g. PLC)
- 2 Ground the cable shield at one end. The cable shield must be grounded at both ends to comply with EMC requirements; observe cable specifications → 20
- 3 Connection for HART operating devices → 50
- 4 Resistor for HART communication ($\geq 250 \Omega$): observe maximum load → 14
- 5 Analog display unit: observe maximum load → 14
- 6 Transmitter

Pulse/frequency output

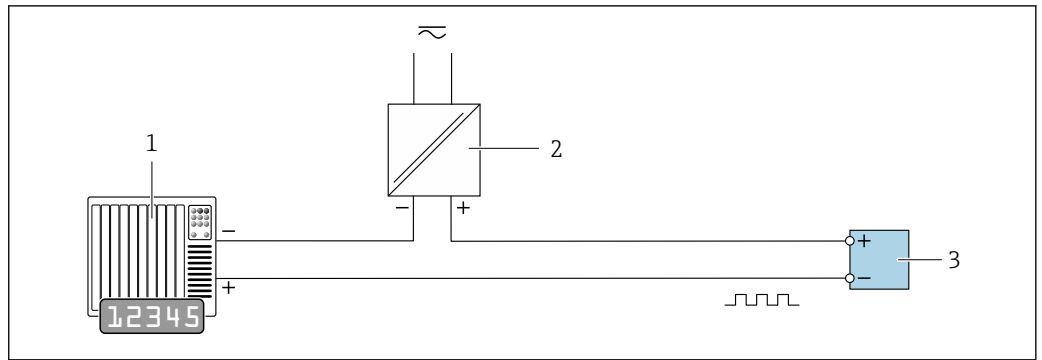

A0028761

14 Connection example for pulse/frequency output (passive)

- 1 Automation system with pulse/frequency input (e.g. PLC)
- 2 Power supply
- 3 Transmitter: Observe input values → 14

Switch output

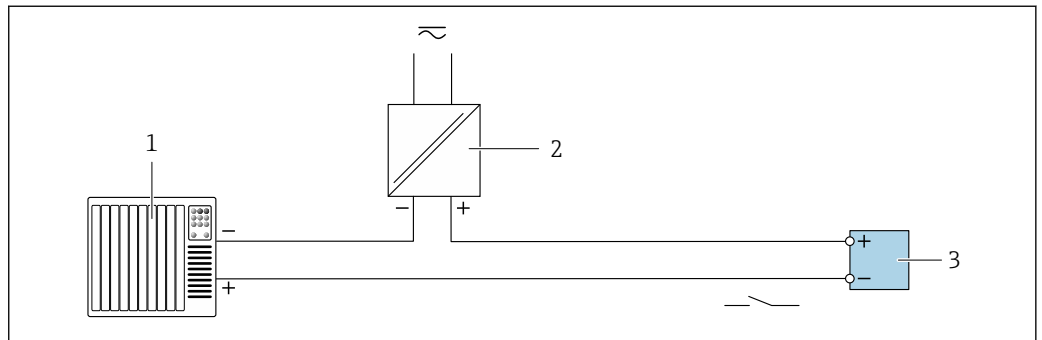

A0028760

15 Connection example for switch output (passive)

- 1 Automation system with switch input (e.g. PLC)
- 2 Power supply
- 3 Transmitter: Observe input values → 14

Status input

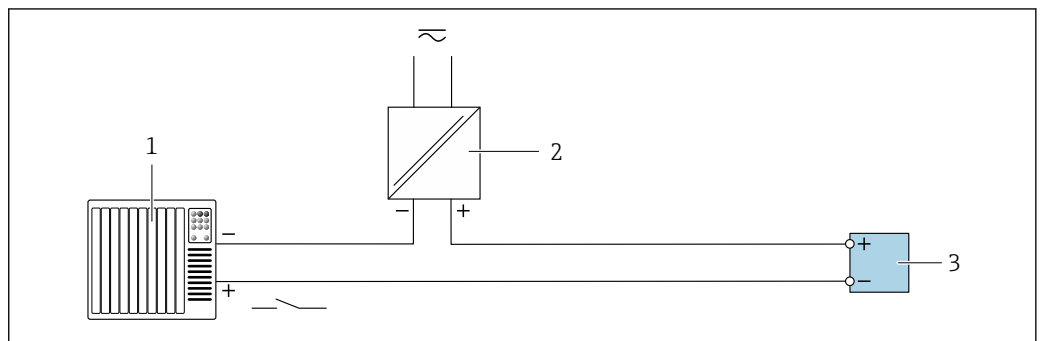

A0028764

16 Connection example for status input

- 1 Automation system with status output (e.g. PLC)
- 2 Power supply
- 3 Transmitter

Potential equalization**Requirements**

For potential equalization:

- Pay attention to in-house grounding concepts
- Take account of operating conditions like the pipe material and grounding
- Connect the sensor and transmitter to the same electrical potential
- Use a ground cable with a minimum cross-section of 6 mm² (0.0093 in²) for the potential equalization connections

Terminals**Transmitter**

Supply voltage cable: plug-in spring terminals for wire cross-sections 0.5 to 2.5 mm² (20 to 14 AWG)

Cable entries**Cable entry thread**

- M20 x 1.5
- Via adapter:
 - NPT ½"
 - G ½"

Cable gland

M20 × 1.5 with cable ϕ 6 to 12 mm (0.24 to 0.47 in)



If metal cable entries are used, use a grounding plate.

Cable specification**Permitted temperature range**

- The installation guidelines that apply in the country of installation must be observed.
- The cables must be suitable for the minimum and maximum temperatures to be expected.

Power supply cable (incl. conductor for the inner ground terminal)

Standard installation cable is sufficient.

Signal cable

Current output 0/4 to 20 mA

Standard installation cable is sufficient.

Current output 4 to 20 mA HART

A shielded cable is recommended. Observe grounding concept of the plant.

Pulse/frequency/switch output

Standard installation cable is sufficient.

Status input

Standard installation cable is sufficient.

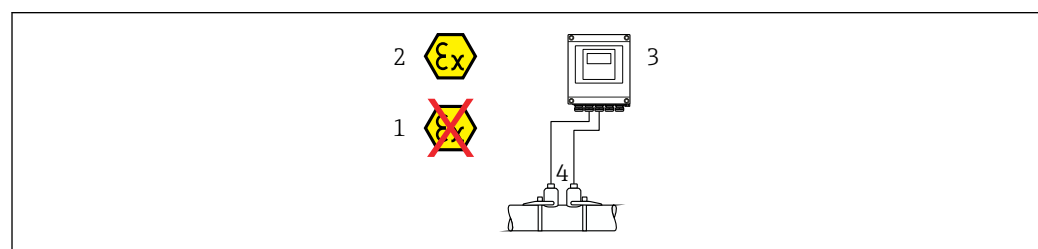
Connecting cable between the transmitter and sensor

A0044949

- 1 Non-hazardous area
- 2 Hazardous area: Zone 2; Class I, Division 2
- 3 Proline 400 transmitter
- 4 Sensor set with sensor cable to transmitter 400 → 21
Transmitter and sensor installed in the hazardous area: Zone 2; Class I, Division 2

Sensor cable for sensor - transmitter



Standard cable	<ul style="list-style-type: none"> ■ TPE: -40 to +80 °C (-40 to +176 °F) ■ TPE halogen-free: -40 to +80 °C (-40 to +176 °F) ■ PTFE: -40 to +130 °C (-40 to +266 °F)
Cable length (max.)	30 m (90 ft)
Cable lengths (available for order)	5 m (15 ft), 10 m (30 ft), 15 m (45 ft), 30 m (90 ft)
Operating temperature	Depends on the device version and how the cable is installed: Standard version: <ul style="list-style-type: none"> ■ Cable, fixed installation ¹⁾: minimum -40 °C (-40 °F) ■ Cable, movable: minimum -25 °C (-13 °F)

1) Compare details under the "Standard cable" row

Performance characteristics

Reference operating conditions

- Error limits following ISO/DIS 11631
- Specifications as per measurement report
- Accuracy information is based on accredited calibration rigs that are traced to ISO 17025.

 To obtain measured errors, use the *Applicator* sizing tool →  58

Maximum measured error

o.r. = of reading

The measured error depends on a number of factors. A distinction is made between the measured error of the device (0.5% o.r.) and an additional installation-specific measured error (typically 1.5% o.r.) that is independent of the device.

The installation-specific measured error depends on the installation conditions on site, such as the nominal diameter, wall thickness, real pipe geometry or medium. The sum of the two measured errors is the measured error at the measuring point.

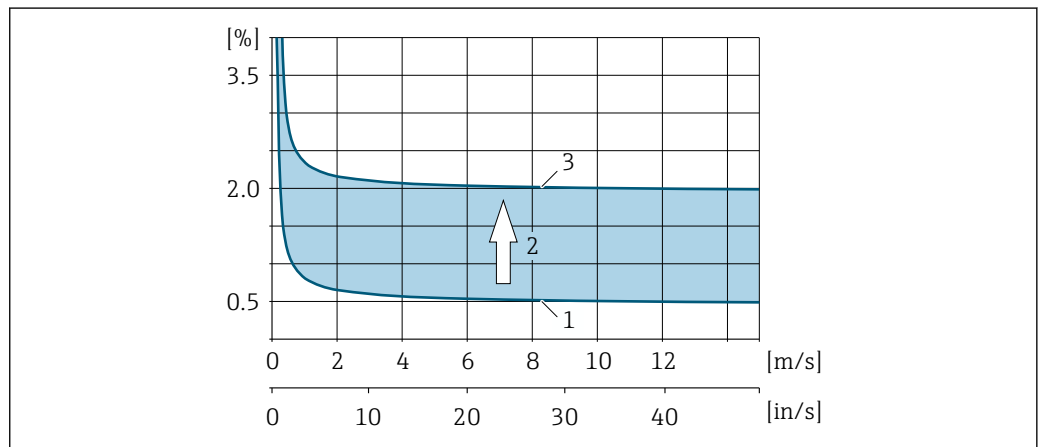

 17 Example of the measured error in a pipe with a nominal diameter DN > 200 (8")

- 1 Measured error of measuring device: 0.5% o.r. ± 3 mm/s (0.12 in/s)
- 2 Measured error due to installation conditions: typically 1.5% o.r.
- 3 Measured error at the measuring point: 0.5% o.r. ± 3 mm/s (0.12 in/s) + 1.5% o.r. = 2% o.r. ± 3 mm/s (0.12 in/s)

Measured error at the measuring point

The measured error at the measuring point is made up of the measured error of the device (0.5% o.r.) and the measured error resulting from the installation conditions on site. With a flow velocity > 0.3 m/s (1 ft/s) and a Reynolds number > 10 000, the following are typical error limits:

Nominal diameter	Device error limits	+	Installation-specific error limits (typical)	→	Error limits at the measuring point (typical)	Field calibration ¹⁾
DN 15 (½")	±0.5% o.r. ± 5 mm/s (0.20 in/s)	+	±2.5% o.r.	→	±3% o.r. ± 5 mm/s (0.20 in/s)	±0.5% o.r. ± 5 mm/s (0.20 in/s)
DN 25 to 200 (1 to 8")	±0.5% o.r. ± 7.5 mm/s (0.30 in/s)	+	±1.5% o.r.	→	±2% o.r. ± 7.5 mm/s (0.30 in/s)	±0.5% o.r. ± 7.5 mm/s (0.30 in/s)
> DN 200 (8")	±0.5% o.r. ± 3 mm/s (0.12 in/s)	+	±1.5% o.r.	→	±2% o.r. ± 3 mm/s (0.12 in/s)	±0.5% o.r. ± 3 mm/s (0.12 in/s)

1) Adjustment in relation to a reference with correction values written back to the transmitter

Measurement report

If required, the device can be supplied with a factory measurement report. A measurement is performed under reference conditions to verify the performance of the device. Here, the sensors are mounted on a pipe with a nominal diameter of DN 50 (2") or DN 100 (4").

With a flow velocity of > 0.3 m/s (1 ft/s) and a Reynolds number > 10 000, the following error limits are guaranteed with the measurement report:

Nominal diameter	Device error limits
50 (2")	±0.5% o.r. ± 5 mm/s (0.20 in/s)
100 (4")	±0.5% o.r. ± 7.5 mm/s (0.30 in/s)

 The specification applies for Reynolds numbers $Re \geq 10\,000$. Larger measured errors can occur for Reynolds numbers $Re < 10\,000$.

Example for max. measured error (volume flow)

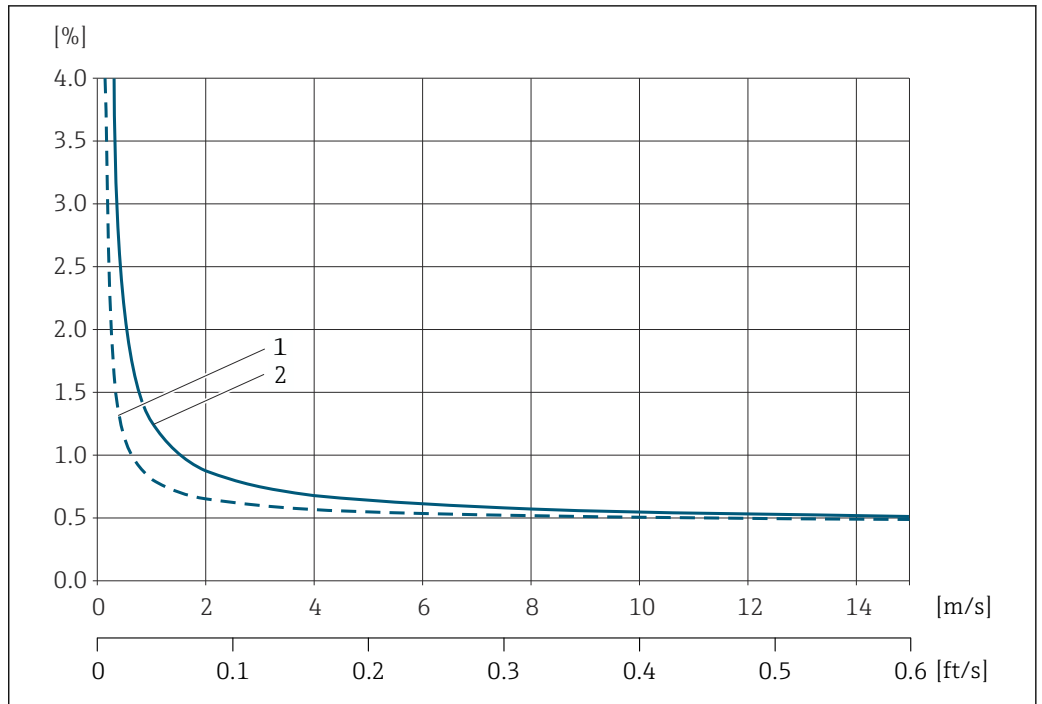

A0041973

18 Example for max. measured error (volume flow) in % o.r.

- 1 Pipe diameter < DN 100 (4")
- 2 Pipe diameter ≥ DN 100 (4")

Repeatability

o.r. = of reading
 ±0.3% for flow velocities >0.3 m/s (1 ft/s)

Influence of ambient temperature

Current output
 o.r. = of reading

Temperature coefficient	Max. ±0.005 % o.r./°C
--------------------------------	-----------------------

Pulse/frequency output

Temperature coefficient	No additional effect. Included in accuracy.
--------------------------------	---

Mounting

Mounting location

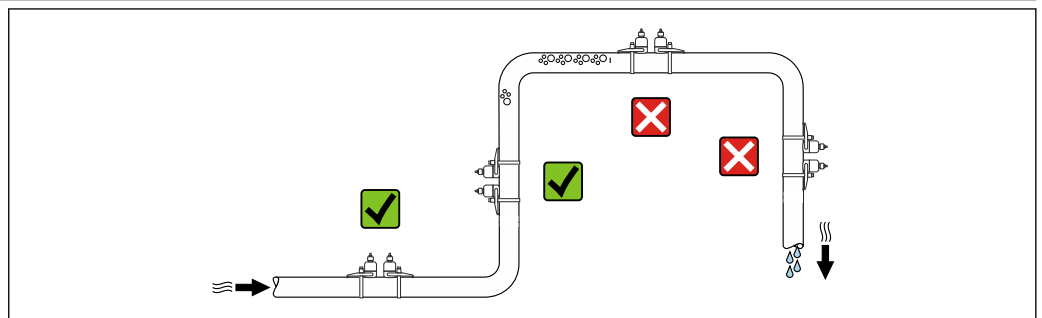

A0042039

To prevent measuring errors arising from accumulation of gas bubbles in the measuring pipe, avoid the following mounting locations in the piping:

- Highest point of a pipeline.
- Directly upstream of a free pipe outlet in a down pipe.

Orientation

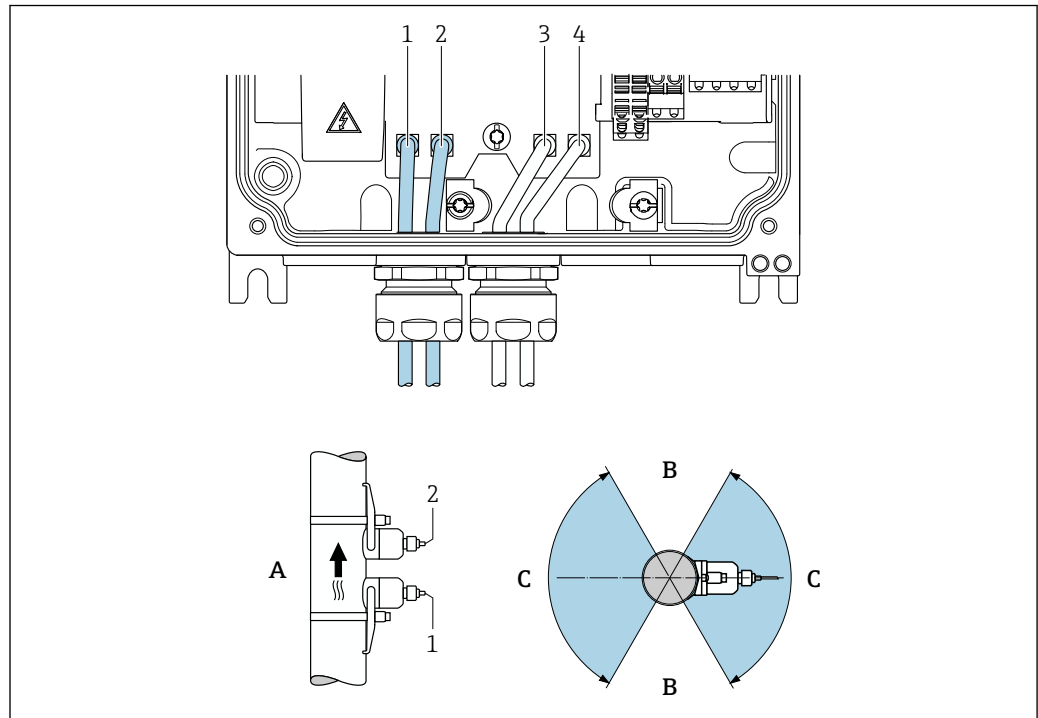

A0045280

19 Orientation views

- 1 Channel 1 upstream
- 2 Channel 1 downstream
- 3 Channel 2 upstream
- 4 Channel 2 downstream
- A Recommended orientation with upward direction of flow
- B Non-recommended installation range with horizontal orientation (60°)
- C Recommended installation range max. 120°

Vertical

Recommended orientation with upward direction of flow (View A). With this orientation, entrained solids will sink and gases will rise away from the sensor area when the medium is not flowing. Furthermore, the pipe can be completely drained and protected against the buildup of deposits.

Horizontal

In the recommended installation range with a horizontal orientation (View B), gas and air accumulations at the top of the pipe and interference from deposit buildup at the bottom of the pipe can influence the measurement to a lesser degree.

Inlet and outlet runs

If possible, the sensor should be installed upstream from valves, T-sections, pumps etc. If this is not possible, the inlet and outlet runs indicated below must be maintained at the very minimum in order to attain the specified level of accuracy of the measuring device. If there are several flow disturbances present, the longest specified inlet run must be maintained.

- i** Shorter inlet and outlet runs are possible with the following device versions:
Two-path measurement with 2 sensor sets⁶⁾ and order code for "Application package", option EN "FlowDC" (for item numbers 1 to 4b):
Up to minimum 2 × DN for inlet run, 2 × DN for outlet run

6) Order code for "Mounting type", option A2 "Clamp-on, 2-channel, 2-sensor sets"

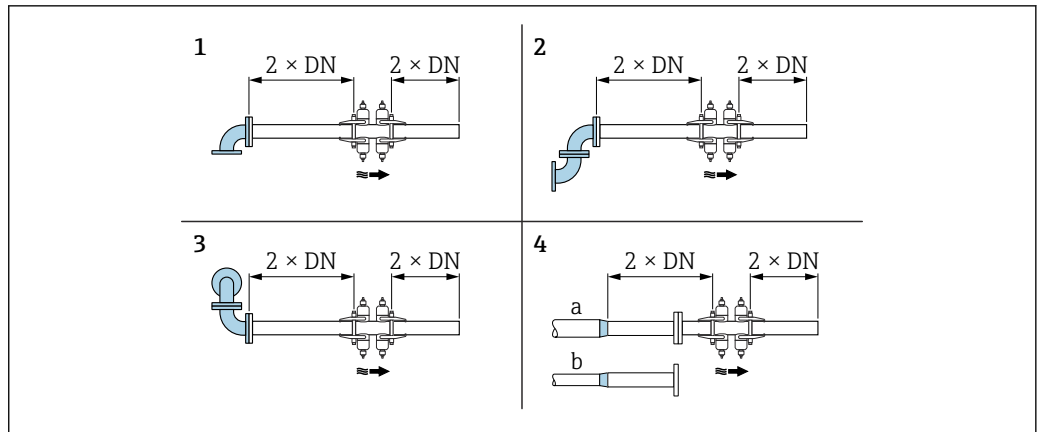

A0044471

20 Minimum inlet and outlet runs with FlowDC with various flow obstructions

- 1 Pipe bend
- 2 Two pipe bends (on one plane)
- 3 Two pipe bends (on two planes)
- 4a Reduction
- 4b Extension

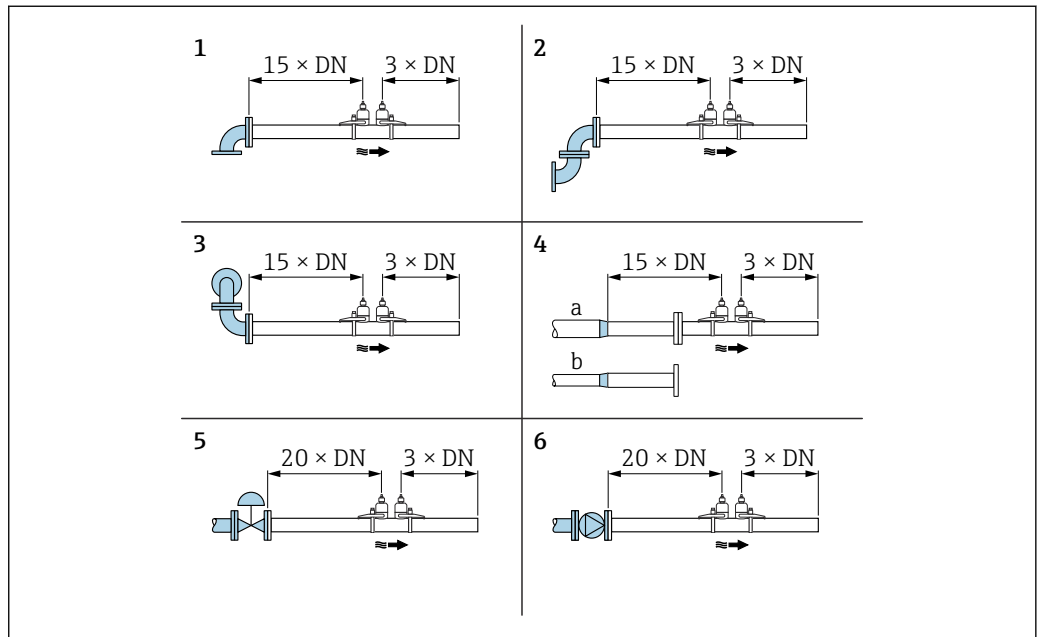

A0042041

21 Minimum inlet and outlet runs without FlowDC with 1 or 2 sensor sets with various flow obstructions

- 1 Pipe bend
- 2 Two pipe bends (on one plane)
- 3 Two pipe bends (on two planes)
- 4a Reduction
- 4b Extension
- 5 Control valve (2/3 open)
- 6 Pump

Mounting the sensor



Risk of injury when mounting the sensors and strapping bands!

- Due to the increased risk of cuts, wear suitable gloves and protective goggles.

Sensor configuration and settings

DN 15 to 65 (½ to 2½")	DN 50 to 4000 (2 to 160")				
	Strapping band	Strapping band		Welded bolt	
2 traverses [mm (in)]	1 traverse [mm (in)]	2 traverses [mm (in)]	1 traverse [mm (in)]	2 traverses [mm (in)]	
Sensor distance ¹⁾	Sensor distance ¹⁾	Sensor distance ¹⁾	Sensor distance ¹⁾	Sensor distance ¹⁾	
–	Wire length →  33	Measuring rail ^{1) 2)}	Wire length	Measuring rail ^{1) 2)}	

- 1) Depends on the conditions at the measuring point (measuring pipe, medium etc.). The dimension can be determined via FieldCare or Applicator. See also the **Result sensor distance / measuring aid** parameter in the **Measuring point** submenu
- 2) Only up to DN 600 (24")

Determining the sensor mounting positions

Sensor holder with U-shaped screws

-  Can be used for
- Measuring devices with measuring range DN 15 to 65 (½ to 2½")
 - Mounting on pipes DN 15 to 32 (½ to 1¼")

Procedure:

1. Disconnect the sensor from the sensor holder.
2. Position the sensor holder on the measuring pipe.
3. Fit the U-shaped screws through the sensor holder and lightly grease the thread.
4. Screw the nuts onto the U-shaped screws.
5. Position the sensor holder correctly and tighten the nuts uniformly.

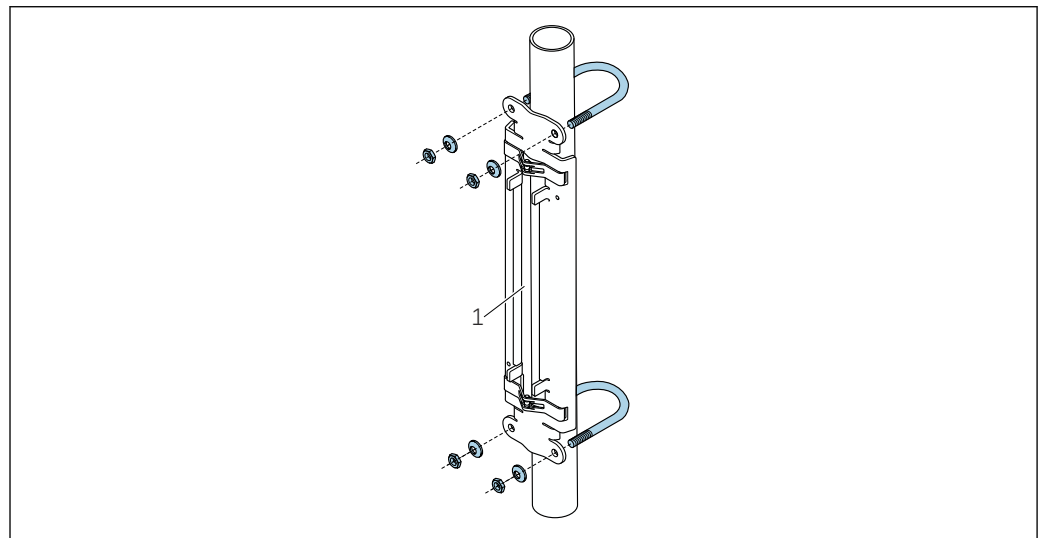

A0043369

 22 Holder with U-shaped screws

1 Sensor holder

CAUTION

Risk of damaging plastic or glass pipes if the nuts on the U-shaped screws are tightened too much!

- ▶ The use of a metal half-shell (on the opposite side of the sensor) is recommended for plastic or glass pipes.

 The visible measuring pipe surface must be clean (free from flaking paint and/or rust) to ensure good acoustic contact.

Sensor holder with strapping bands (small nominal diameters)

- i** Can be used for
 - Measuring devices with measuring range DN 15 to 65 (½ to 2½")
 - Mounting on pipes DN > 32 (1¼")

Procedure:

1. Disconnect the sensor from the sensor holder.
2. Position the sensor holder on the measuring pipe.
3. Wrap the strapping bands around the sensor holder and measuring pipe without twisting them.

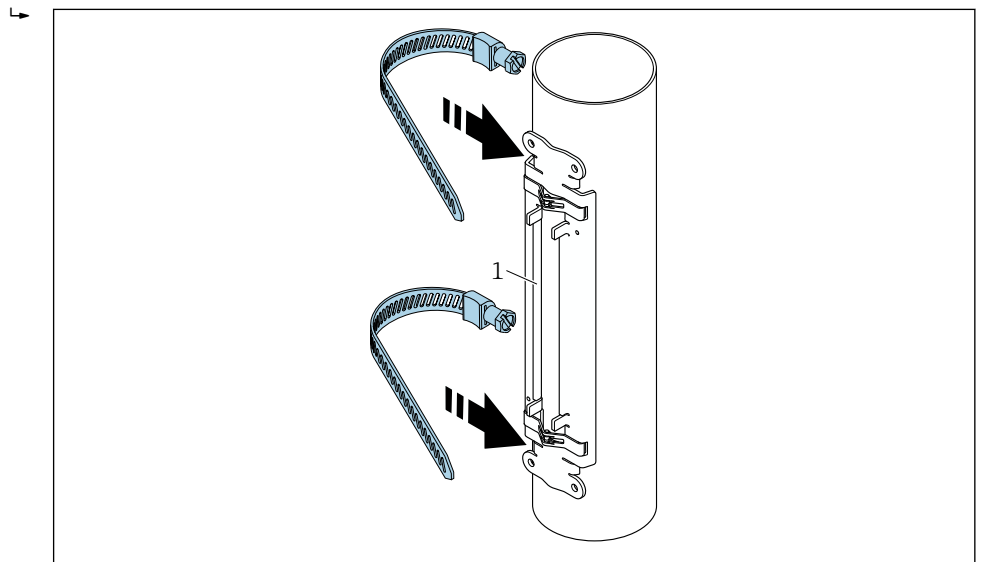

A0043371

23 Positioning the sensor holder and mounting the strapping bands

1 Sensor holder

4. Guide the strapping bands through the strapping band locks.
5. Tighten the strapping bands as tightly as possible by hand.
6. Set the sensor holder to the desired position.
7. Push down the tensioning screw and tighten the strapping bands so they cannot slip.

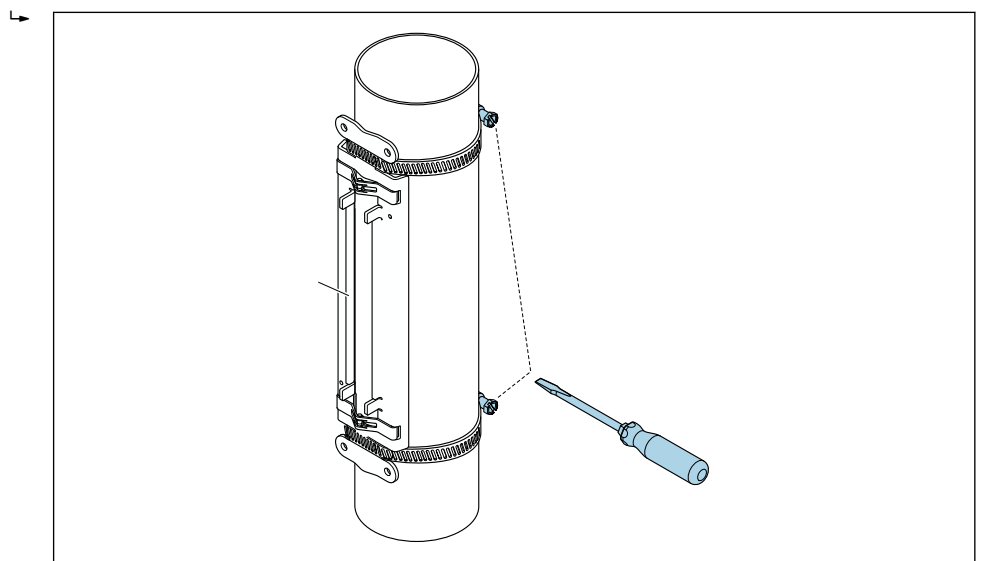

A0043372

24 Tightening the tensioning screws of the strapping bands

8. If necessary, shorten the strapping bands and trim the cut edges.

⚠ WARNING**Risk of injury!**

- ▶ To avoid sharp edges, trim the cut edges after shortening the strapping bands. Wear suitable gloves and protective goggles.

i The visible measuring pipe surface must be clean (free from flaking paint and/or rust) to ensure good acoustic contact.

Sensor holder with strapping bands (medium nominal diameters)

- i** Can be used for
- Measuring devices with measuring range DN 50 to 4000 (2 to 160")
 - Mounting on pipes DN ≤ 600 (24")

Procedure:

1. Fit the mounting bolt over strapping band 1.
2. Position strapping band 1 as perpendicular as possible to the measuring pipe axis without twisting it.
3. Guide the end of strapping band 1 through the strapping band lock.
4. Tighten strapping band 1 as tightly as possible by hand.
5. Set strapping band 1 to the desired position.
6. Push down the tensioning screw and tighten strapping band 1 so it cannot slip.
7. Strapping band 2: proceed as for strapping band 1 (steps 1 to 6).
8. Only slightly tighten strapping band 2 for final mounting. It must be possible to move strapping band 2 for final alignment.
9. If necessary, shorten both strapping bands and trim the cut edges.

⚠ WARNING**Risk of injury!**

- ▶ To avoid sharp edges, trim the cut edges after shortening the strapping bands. Wear suitable gloves and protective goggles.

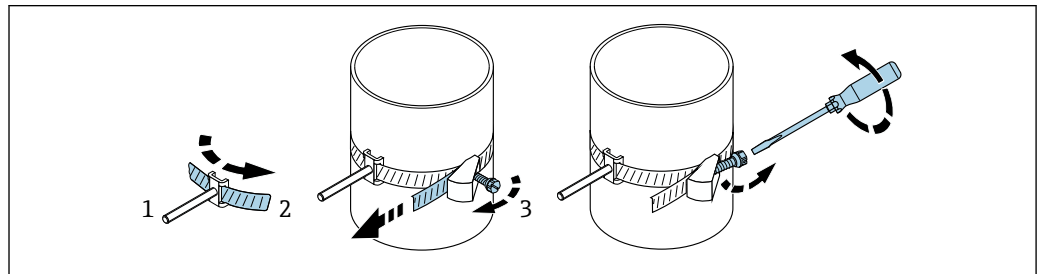

A0043373

25 *Holder with strapping bands (medium nominal diameters), with hinged screw*

- 1 Mounting bolts
2 Strapping band
3 Tensioning screw

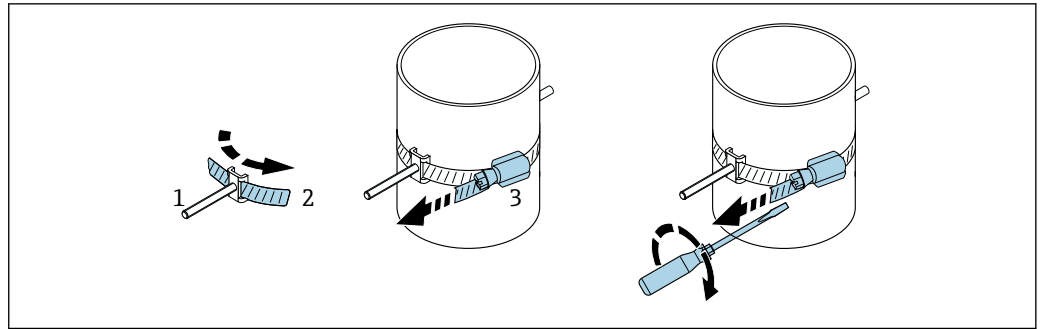

A0044350

26 Holder with strapping bands (medium nominal diameters), without hinged screw

- 1 Mounting bolts
- 2 Strapping band
- 3 Tensioning screw

Sensor holder with strapping bands (large nominal diameters)

- i** Can be used for
 - Measuring devices with measuring range DN 50 to 4000 (2 to 160")
 - Mounting on pipes DN > 600 (24")
 - 1-traverse mounting or 2-traverse mounting with 180° arrangement
 - 2-traverse mounting with two-path measurement and 90° arrangement (instead of 180°)

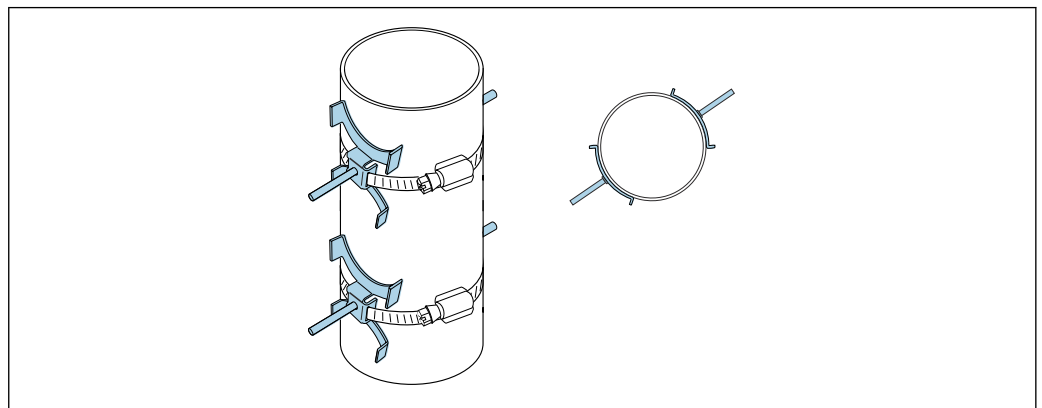

A0044648

Procedure:

1. Measure the pipe circumference. Note down the full/half or quarter circumference.
2. Cut the strapping bands to length (= pipe circumference + 30 mm (1.18 in)) and trim the cut edges.
3. Select the mounting location of the sensors with the given sensor distance and optimum inlet run conditions, while ensuring there is nothing impeding sensor mounting over the entire circumference of the measuring pipe.
4. Fit two strap bolts over strapping band 1 and guide approx. 50 mm (2 in) of one of the strapping band ends through one of the two strapping band locks and into the buckle. Then guide the protective flap over this strapping band end and lock in place.
5. Position strapping band 1 as perpendicular as possible to the measuring pipe axis without twisting it.
6. Guide the second strapping band end through the strapping band lock that is still free and proceed in the same way as for the first strapping band end. Guide the protective flap over the second strapping band end and lock in place.
7. Tighten strapping band 1 as tightly as possible by hand.
8. Set strapping band 1 to the desired position, ensuring that it is as perpendicular as possible to the measuring pipe axis.

9. Position the two strap bolts on strapping band 1, arranging them at a half circumference in relation to one another (180° arrangement, e.g. clock hands positioned at 7:30 and 1:30) or quarter circumference (90° arrangement, e.g. clock hands positioned at 10 o'clock and 7 o'clock).
10. Tighten strapping band 1 so that it cannot slip.
11. Strapping band 2: proceed as for strapping band 1 (steps 4 to 8).
12. Only slightly tighten strapping band 2 for final mounting so that it can still be adjusted. The distance/offset from the center of strapping band 2 to the center of strapping band 1 is indicated by the sensor distance of the device.
13. Align strapping band 2 so that it is perpendicular to the measuring pipe axis and parallel to strapping band 1.
14. Position the two strap bolts on strapping band 2 on the measuring pipe so they are parallel to one another and offset at the same height/clock position (e.g. 10 and 4 o'clock) in relation to the two strap bolts on strapping band 1. A line drawn on the measuring pipe wall that is parallel to the measuring pipe axis can be helpful here. Now set the distance between the center of the strap bolts at the same level so that it exactly matches the sensor distance. An alternative method is to use the wire length →  33.
15. Tighten strapping band 2 so that it cannot slip.

⚠ WARNING

Risk of injury!



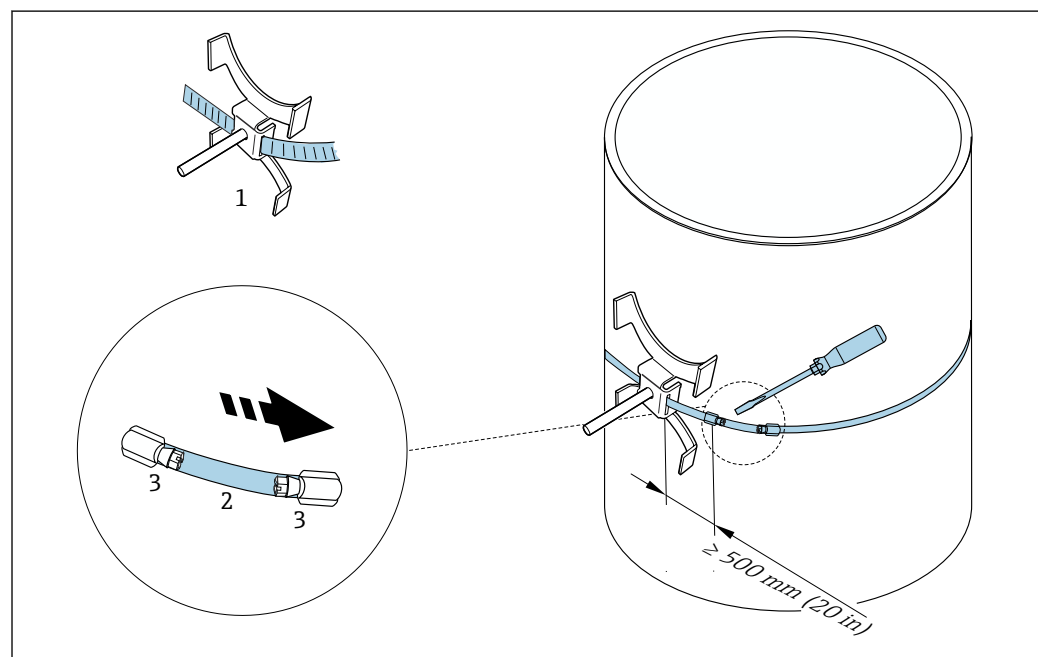





- ▶ To avoid sharp edges, trim the cut edges after shortening the strapping bands. Wear suitable gloves and protective goggles.



 27 Holder with strapping bands (large nominal diameters)

- 1 Strap bolt with guide*
- 2 Strapping band*
- 3 Tensioning screw

*The distance between the strap bolt and strapping band lock must be at least 500 mm (20 in).

-  For 1-traverse mounting with 180° (opposite) →  4,  7 (single-path measurement, A0044304), →  8,  8 (two-path measurement, A0043168)
- For 2-traverse mounting →  5,  7 (single-path measurement, A0044305), →  9,  8 (two-path measurement, A0043309)
- Electrical connection

Sensor holder with welded bolts



Can be used for

- Measuring devices with measuring range DN 50 to 4000 (2 to 160")
- Mounting on pipes DN 50 to 4000 (2 to 160")

Procedure:

- The welded bolts must be fixed at the same installation distances as the mounting bolts with strapping bands. The following sections explain how to align the mounting bolts, depending on the mounting method and measurement method:
 - Installation for measurement via 1 traverse → 33
 - Installation for measurement via 2 traverses → 35
- The sensor holder is secured as standard with a locking nut with a metric M6 ISO thread. If another thread should be used for fastening purposes, a sensor holder with a detachable locking nut must be used.

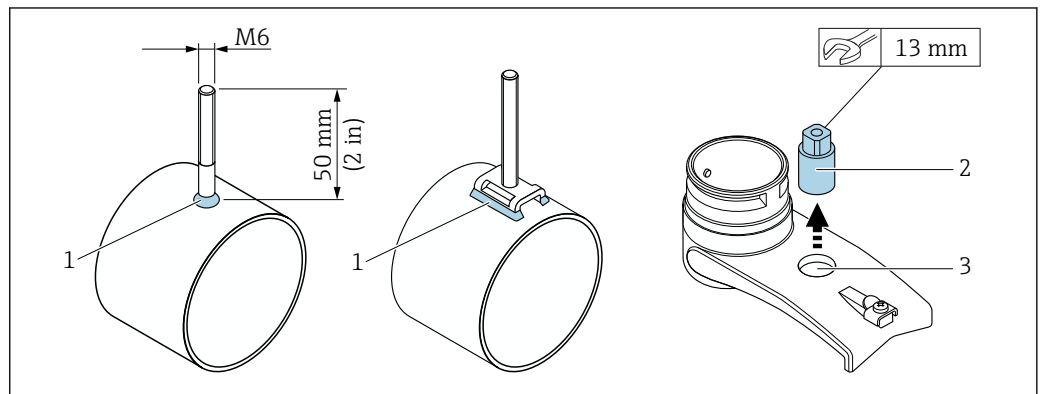

28 Holder with welded bolts

- 1 Welding seam
- 2 Locking nut
- 3 Hole diameter max. 8.7 mm (0.34 in)

Sensor installation – small nominal diameters DN 15 to 65 (½ to 2½")

Requirements

- The installation clearance is known → 26
- The sensor holder is pre-installed

Material

The following material is required for mounting:

- Sensor incl. adapter cable
- Sensor cable for connecting to the transmitter
- Coupling medium (coupling pad or coupling gel) for an acoustic connection between the sensor and pipe

Procedure:

1. Set the distance between the sensors to the value determined for the sensor distance. Press the movable sensor down slightly to move it.

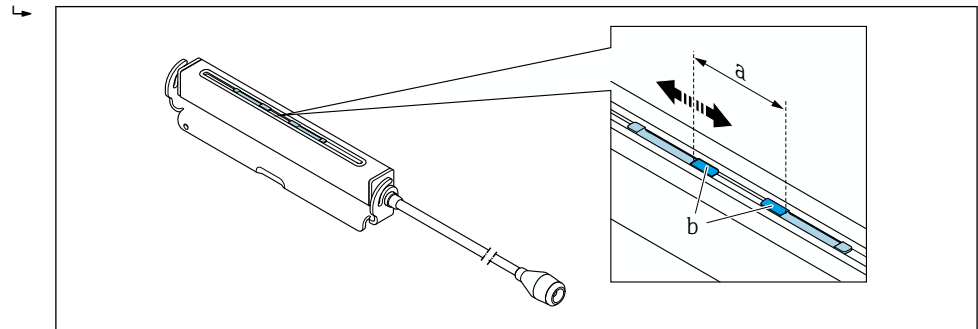

A0043376

☞ 29 Distance between sensors as per the installation clearance → ☞ 26

a Sensor distance (back of sensor must touch the surface)

b Sensor contact surfaces

2. Stick the coupling pad under the sensor to the measuring pipe or coat the contact surfaces of the sensor (b) with an even layer of coupling gel (approx. 0.5 to 1 mm (0.02 to 0.04 in)).
3. Fit the sensor housing on the sensor holder.

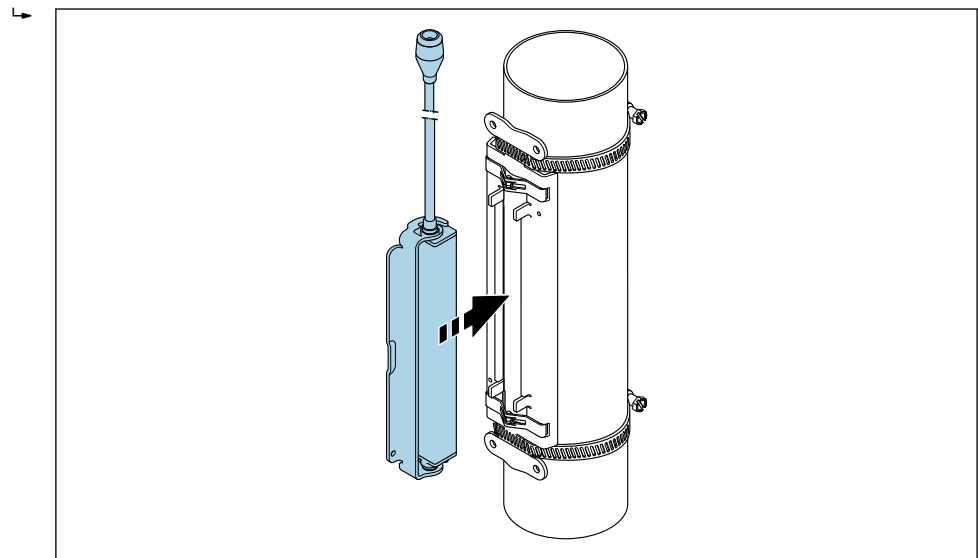

A0043377

☞ 30 Fitting the sensor housing

4. Lock the bracket in place to fix the sensor housing on the sensor holder.

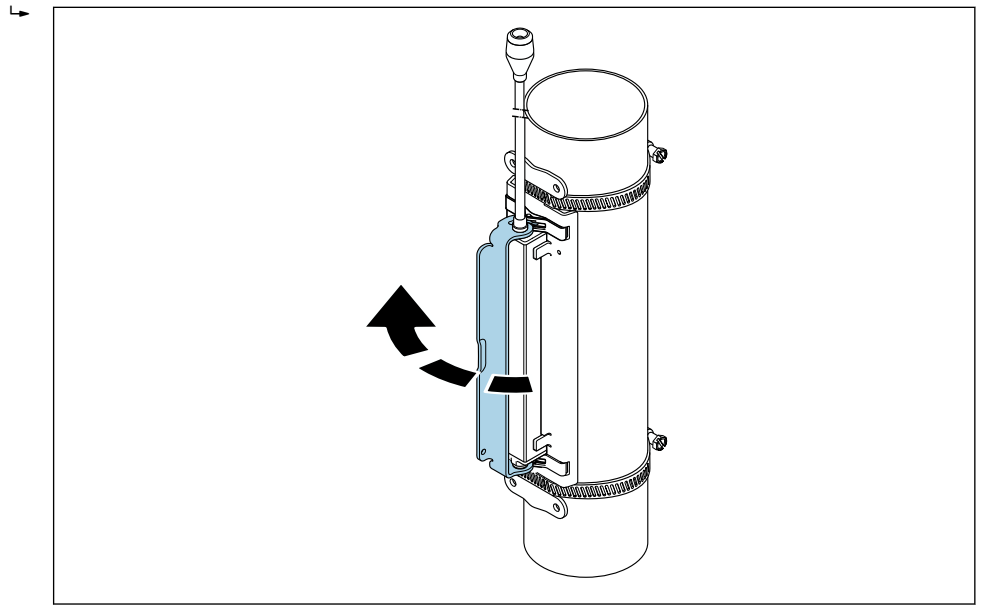

A0043378

31 Fixing the sensor housing

5. Connect the sensor cable to the adapter cable.

↳ This completes the mounting procedure. The sensors can now be connected to the transmitter via the connecting cables.

- i
 - The visible measuring pipe surface must be clean (free from flaking paint and/or rust) to ensure good acoustic contact.
 - If necessary, the holder and sensor housing can be secured with a screw/nut or a lead seal (not supplied).
 - The bracket can only be released using an auxiliary tool (e.g. screwdriver).

Sensor installation – medium/large nominal diameters DN 50 to 4000 (2 to 160")

Installation for measurement via 1 traverse

Requirements

- The installation clearance and wire length are known → 26
- Strapping bands are pre-installed

Material

The following material is required for mounting:

- Two strapping bands incl. mounting bolts and centering plates where necessary (already pre-installed → 28, → 29)
- Two measuring wires, each with a cable lug and a fixer to fix the strapping bands
- Two sensor holders
- Coupling medium (coupling pad or coupling gel) for an acoustic connection between the sensor and pipe
- Two sensors incl. connecting cables

- i
 - Installation is unproblematic up to DN 400 (16"), as of DN 400 (16") check the distance and angle (180°) diagonally with the wire length.

Procedure:

1. Prepare the two measuring wires: arrange the cable lugs and fixer such that the distance they are apart corresponds to the wire length (SL). Screw the fixer onto the measuring wire.

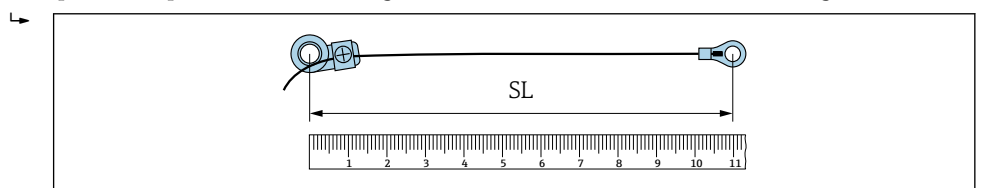

A0043379

32 Fixer and cable lugs at a distance that corresponds to the wire length (SL)

2. With measuring wire 1: fit the fixer over the mounting bolt of strapping band 1 that is already securely mounted. Run measuring wire 1 clockwise around the measuring pipe. Fit the cable lug over the mounting bolt of strapping band 2 that can still be moved.
3. With measuring wire 2: fit the cable lug over the mounting bolt of strapping band 1 that is already securely mounted. Run measuring wire 2 counterclockwise around the measuring pipe. Fit the fixer over the mounting bolt of strapping band 2 that can still be moved.
4. Take the still movable strapping band 2, incl. the mounting bolt, and move it until both measuring wires are evenly tensioned and then tighten strapping band 2 so that it cannot slip. Then check the sensor distance from the center of the strapping bands. If the distance is too small, release strapping band 2 again and position it better. Both strapping bands should be as perpendicular as possible to the measuring pipe axis and parallel to one another.

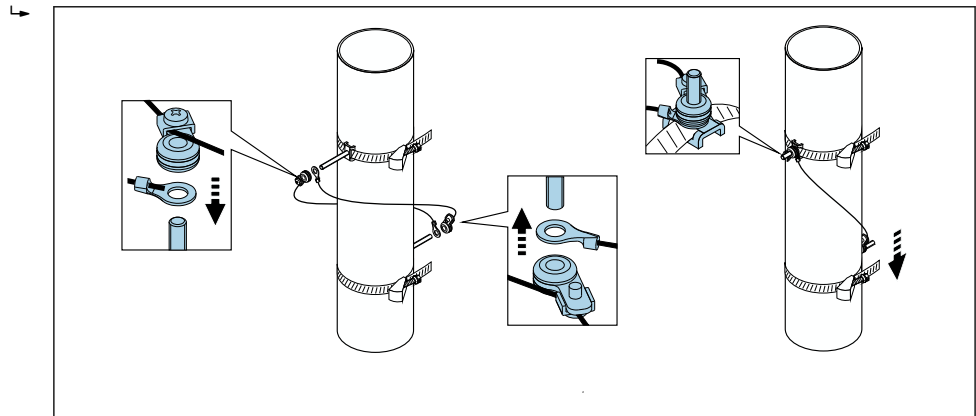

A0043380

☐ 33 Positioning the strapping bands (steps 2 to 4)

5. Loosen the screws of the fixers on the measuring wires and remove the measuring wires from the mounting bolt.
6. Fit the sensor holders over the individual mounting bolts and tighten securely with the locking nut.

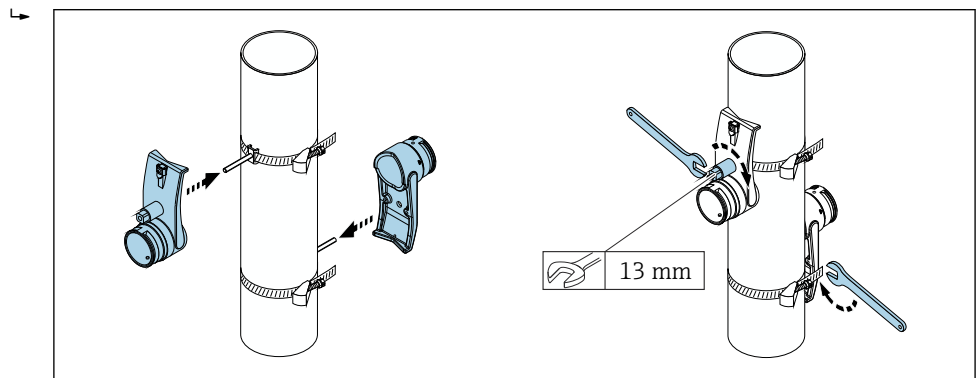

A0043381

☐ 34 Mounting the sensor holders

7. Apply the coupling pad to the sensors with the adhesive side facing down (→ ☐ 60). Alternatively coat the contact surfaces with an even layer of coupling gel (approx. 1 mm (0.04 in)). going from the groove through the center to the opposite edge.

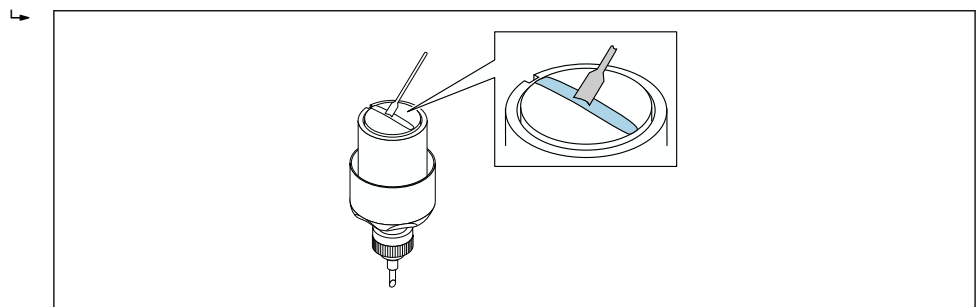

A0043382

☐ 35 Coating the contact surfaces of the sensor with coupling gel (if there is no coupling pad)

8. Insert the sensor into the sensor holder.

9. Fit the sensor cover on the sensor holder and turn until the sensor cover engages with a click and the arrows (▲ / ▼ "close") are pointing towards one another.
10. Insert the sensor cable into the sensor until the end stop.

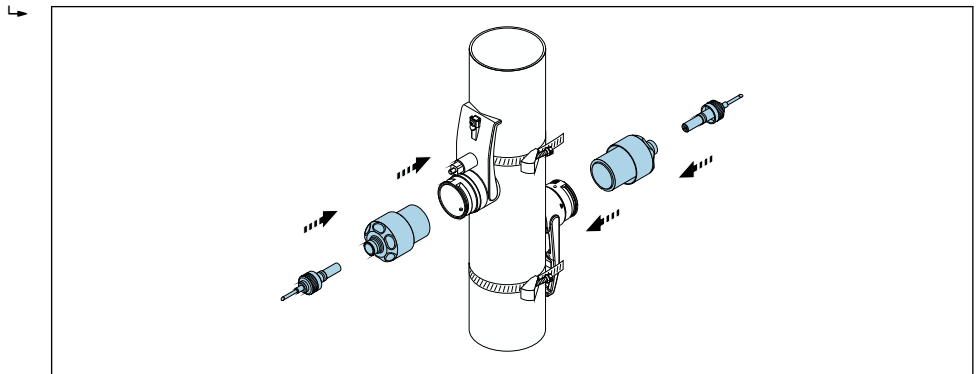

36 Mounting the sensor and connecting the sensor cable

The sensors can now be connected to the transmitter via the sensor cables and the error message can be checked in the sensor check function. This completes the mounting procedure.

- i
 - The visible measuring pipe surface must be clean (free from flaking paint and/or rust) to ensure good acoustic contact.
 - If the sensor is removed from the measuring pipe, it must be cleaned and new coupling gel applied (if there is no coupling pad).
 - On rough measuring pipe surfaces, the gaps in the rough surface must be filled with sufficient amounts of coupling gel if the use of the coupling pad does not suffice (installation quality check).

Installation for measurement via 2 traverses

Requirements

- The installation clearance is known → 26
- Strapping bands are pre-installed

Material

The following material is required for mounting:

- Two strapping bands incl. mounting bolts and centering plates where necessary (already pre-installed → 28, → 29)
- A mounting rail to position the strapping bands:
 - Short rail up to DN 200 (8")
 - Long rail up to DN 600 (24")
 - No rail > DN 600 (24"), as distance measured by sensor distance between the mounting bolts
- Two mounting rail holders
- Two sensor holders
- Coupling medium (coupling pad or coupling gel) for an acoustic connection between the sensor and pipe
- Two sensors incl. connecting cables
- Open-ended wrench (13 mm)
- Screwdriver

Procedure:

1. Position the strapping bands using the mounting rail [only DN50 to 600 (2 to 24"), for larger nominal diameters, measure the distance between the center of the strap bolts directly]: Fit the mounting rail with the bore identified by the letter (from the **Result sensor distance / measuring aid** parameter) over the mounting bolt of strapping band 1 that is fixed in place. Position the adjustable strapping band 2 and fit the mounting rail with the bore identified by the numerical value over the mounting bolt.

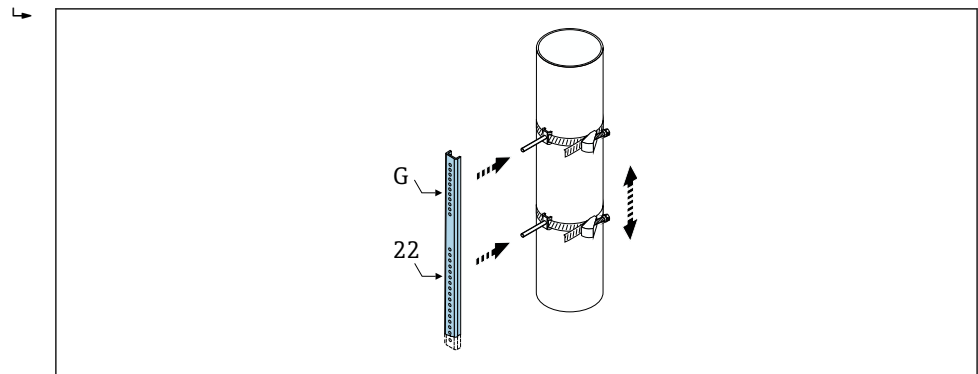

37 Determining the distance according to the mounting rail (e.g. G22)

2. Tighten strapping band 2 so that it cannot slip.
3. Remove the mounting rail from the mounting bolt.
4. Fit the sensor holders over the individual mounting bolts and tighten securely with the locking nut.
5. Apply the coupling pad to the sensors with the adhesive side facing down (→ 60). Alternatively coat the contact surfaces with an even layer of coupling gel (approx. 1 mm (0.04 in)), going from the groove through the center to the opposite edge.

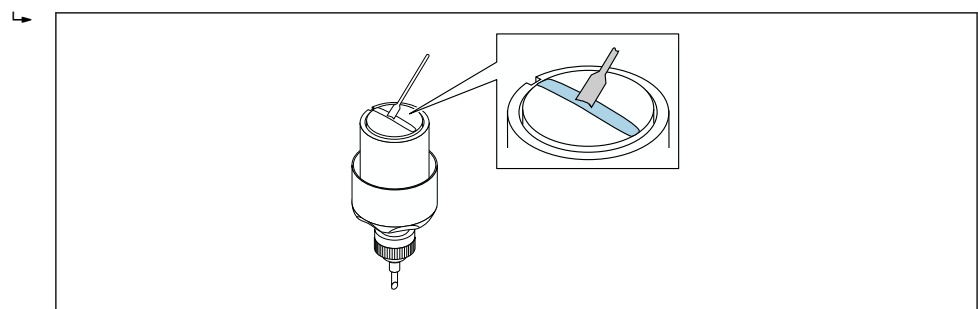

38 Coating the contact surfaces of the sensor with coupling gel (if there is no coupling pad)

6. Insert the sensor into the sensor holder.
7. Fit the sensor cover on the sensor holder and turn until the sensor cover engages with a click and the arrows (▲ / ▼ "close") are pointing towards one another.

8. Insert the sensor cable into the sensor until the end stop and tighten the union nut.

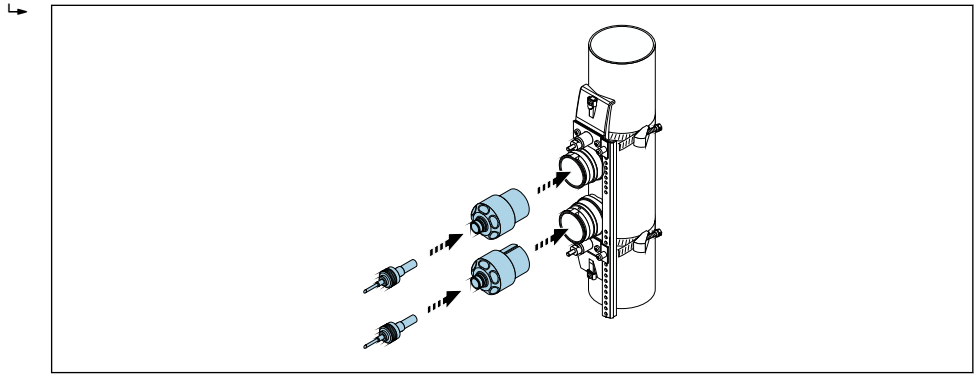

39 Mounting the sensor and connecting the sensor cable

The sensors can now be connected to the transmitter via the sensor cables and the error message can be checked in the sensor check function. This completes the mounting procedure.

- i** The visible measuring pipe surface must be clean (free from flaking paint and/or rust) to ensure good acoustic contact.
- If the sensor is removed from the measuring pipe, it must be cleaned and new coupling gel applied (if there is no coupling pad).
- On rough measuring pipe surfaces, the gaps in the rough surface must be filled with sufficient amounts of coupling gel if the use of the coupling pad does not suffice (installation quality check).

Mounting the transmitter housing

Wall mounting

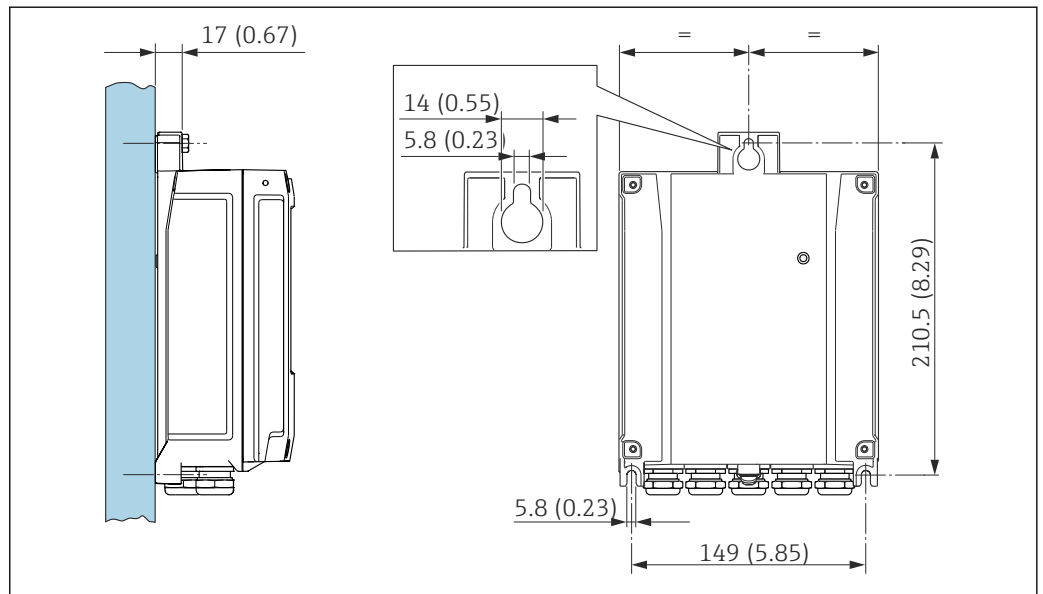

40 Engineering unit mm (in)

Post mounting

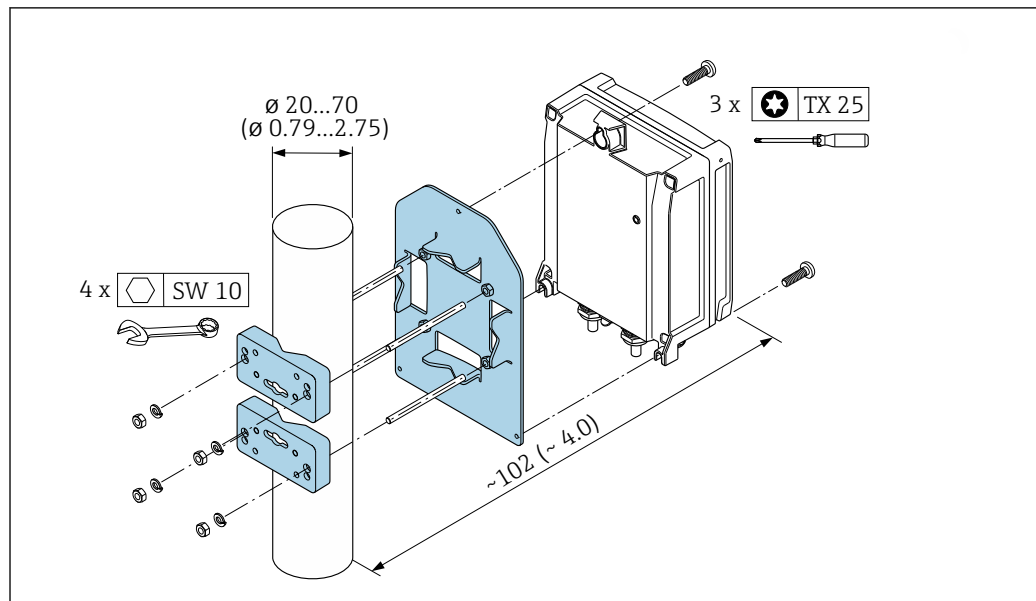

A0029051

41 Engineering unit mm (in)

Special mounting instructions

Display guard

To ensure that the display guard can be easily opened, maintain the following minimum head clearance: 350 mm (13.8 in)

Environment

Ambient temperature range

Transmitter	-40 to +60 °C (-40 to +140 °F)
Readability of the local display	-20 to +60 °C (-4 to +140 °F) The readability of the display may be impaired at temperatures outside the temperature range.
Sensor	DN 15 to 65 (½ to 2½") -40 to +130 °C (-40 to +266 °F) DN 50 to 4000 (2 to 160") <ul style="list-style-type: none"> ■ Standard: -20 to +80 °C (-4 to +176 °F) ■ Optional: -40 to +130 °C (-40 to +266 °F)
Sensor cable (connection between transmitter and sensor)	DN 15 to 65 (½ to 2½") Standard (TPE): -40 to +80 °C (-40 to +176 °F) DN 50 to 4000 (2 to 160") <ul style="list-style-type: none"> ■ Standard (TPE halogen-free): -40 to +80 °C (-40 to +176 °F) ■ Optional (PTFE): -40 to +130 °C (-40 to +266 °F)

i In principle, it is permitted to insulate the sensors mounted on the pipe. In the case of insulated sensors, make sure that the process temperature does not exceed or drop below the specified cable temperature.

- ▶ If operating outdoors:
Avoid direct sunlight, particularly in warm climatic regions.

Storage temperature

The storage temperature for all components (except display modules) corresponds to the ambient temperature range → 38.

Degree of protection

Transmitter

- IP66/67, Type 4X enclosure, suitable for pollution degree 4
- When the housing is open: IP20, Type 1 enclosure, suitable for pollution degree 2
- Display module: IP20, Type 1 enclosure, suitable for pollution degree 2

Sensor

- Standard: IP66/67, Type 4X enclosure, suitable for pollution degree 4
- Optionally available: IP68, Type 6P enclosure, suitable for pollution degree 4

External WLAN antenna

IP67

Vibration- and shock-resistance

Vibration sinusoidal, according to IEC 60068-2-6

- 2 to 8.4 Hz, 7.5 mm peak
- 8.4 to 2 000 Hz, 2 g peak for transmitter, 1 g peak for sensor

Vibration broad-band random, according to IEC 60068-2-64

- 10 to 200 Hz, 0.01 g²/Hz
- 200 to 2 000 Hz, 0.003 g²/Hz
- Total: 2.70 g rms

Shock half-sine, according to IEC 60068-2-27

6 ms 50 g

Rough handling shocks according to IEC 60068-2-31

Electromagnetic compatibility (EMC)

- As per IEC/EN 61326
- Complies with emission limits for industry as per EN 55011 (Class A)



Details are provided in the Declaration of Conformity.

Process

Medium temperature range

Sensor version	Frequency	Temperature
C-030-A	0.3 MHz	-20 to +80 °C (-4 to +176 °F) -40 to +80 °C (-40 to +176 °F)
C-050-A	0.5 MHz	-20 to +80 °C (-4 to +176 °F)
C-100-A	1 MHz	-20 to +80 °C (-4 to +176 °F)
C-200-A	2 MHz	-20 to +80 °C (-4 to +176 °F)
C-500-A	5 MHz	-20 to +80 °C (-4 to +176 °F) -40 to +80 °C (-40 to +176 °F) 0 to +130 °C (+32 to +266 °F)
C-100-B	1 MHz	-40 to +80 °C (-40 to +176 °F)
C-200-B	2 MHz	-40 to +80 °C (-40 to +176 °F)
C-100-C	1 MHz	0 to +130 °C (+32 to +266 °F)
C-200-C	2 MHz	0 to +130 °C (+32 to +266 °F)

Sound velocity range

600 to 2 100 m/s (1 969 to 6 890 ft/s)

Medium pressure range

No pressure limitation. Nevertheless, for correct measurement, the static pressure of the medium must be higher than the vapor pressure.

Pressure loss

There is no pressure loss.

Mechanical construction

Dimensions in SI units

Transmitter remote version

Order code for "Housing", option N "Remote, polycarbonate" or option P "Remote, aluminum coated"

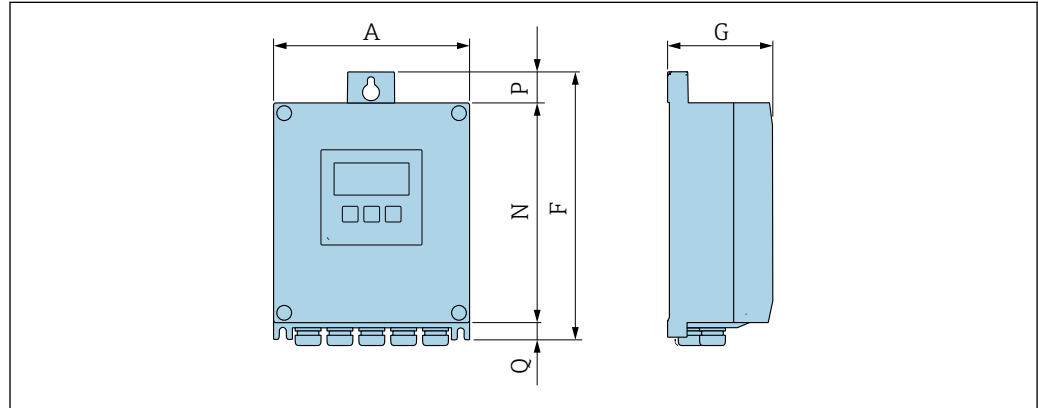

Order code for "Transmitter housing", option P "Remote, aluminum, coated"

A [mm]	F [mm]	G [mm]	N [mm]	P [mm]	Q [mm]
167	232	80	187	24	21

Order code for "Transmitter housing", option N "Remote, polycarbonate"

A [mm]	F [mm]	G [mm]	N [mm]	P [mm]	Q [mm]
177	234	90	197	17	22

Sensor remote version

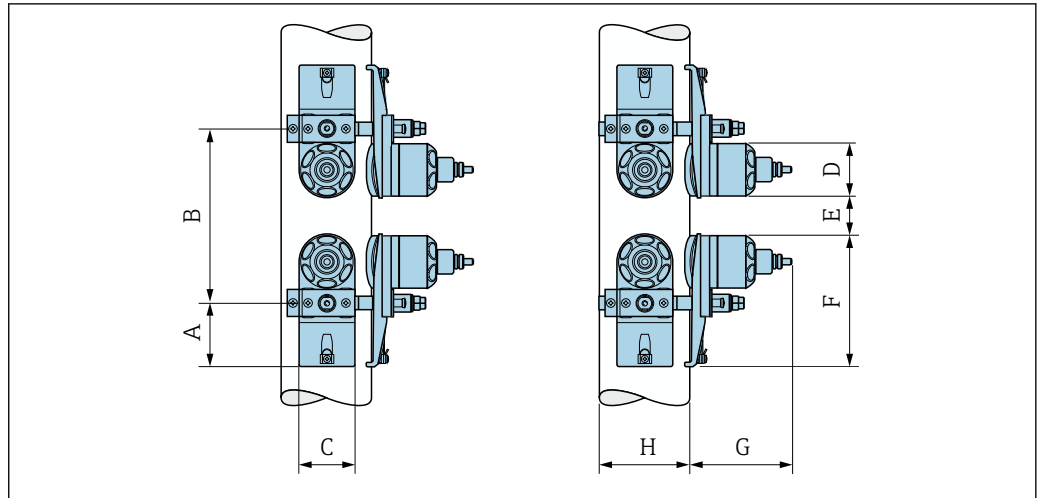

A0041969

42 DN 50 to 4000: measurement with 2 sensor sets

A [mm]	B [mm]	C [mm]	D [mm]	E _{min} [mm]	F [mm]	G [mm]	H [mm]
56	* 1)	62	∅ 58	0.5	145	111	Measuring pipe outer diameter

- 1) Depends on the conditions at the measuring point (measuring pipe, medium etc.). The dimension can be determined via FieldCare or Applicator.

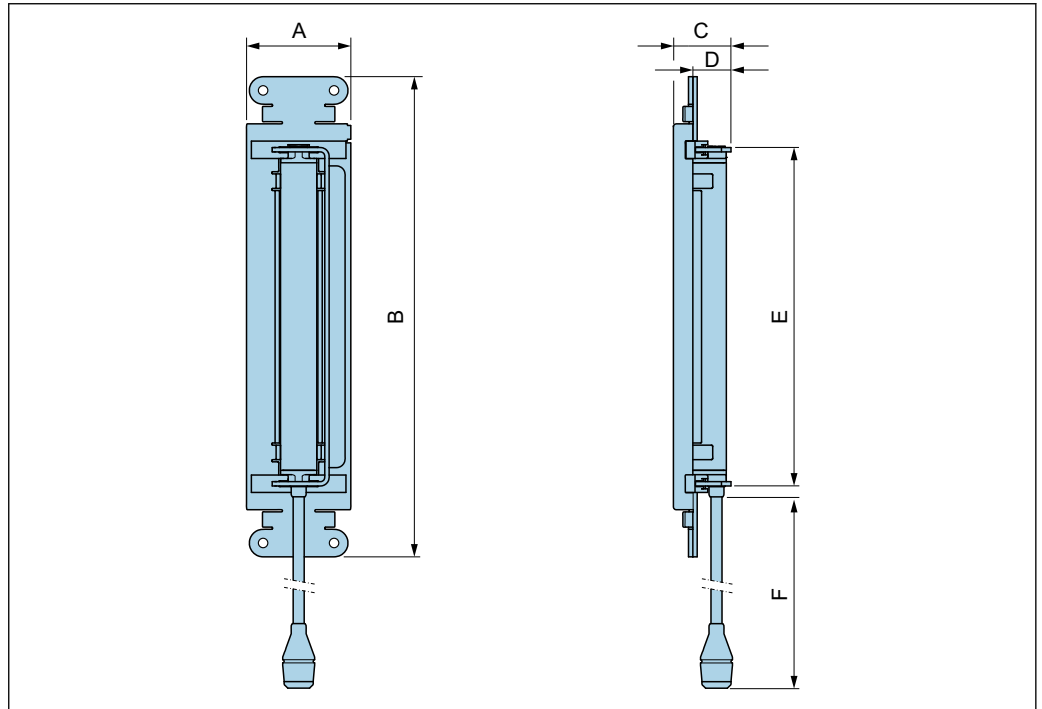

A0041968

43 DN 15 to 65

A [mm]	B [mm]	C [mm]	D [mm]	E [mm]	F [mm]
72	331	39	28	233	450

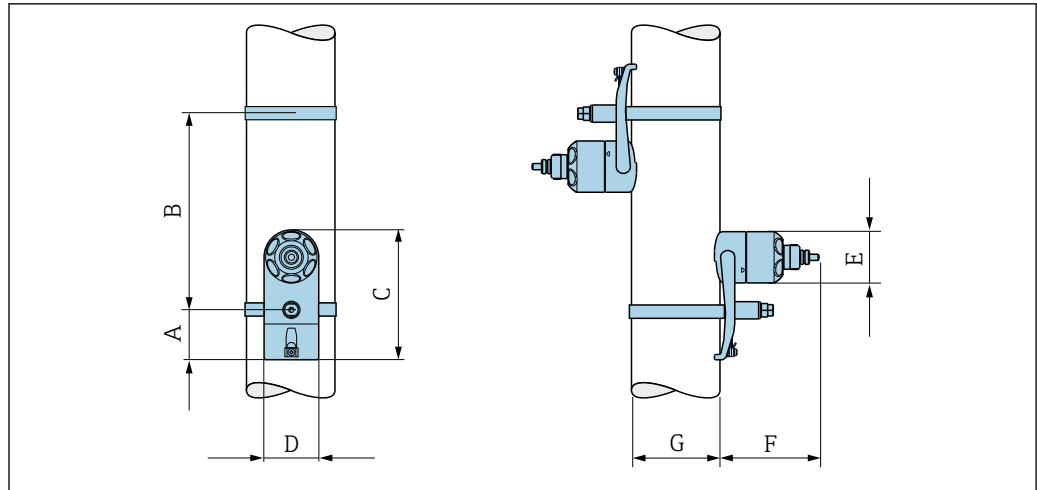

A0041967

44 DN 50 to 4000: measurement with 1 sensor set

A [mm]	B [mm]	C [mm]	D [mm]	E [mm]	F [mm]	G [mm]
56	* 1)	145	62	∅ 58	111	Measuring pipe outer diameter

- 1) Depends on the conditions at the measuring point (measuring pipe, medium etc.). The dimension can be determined via FieldCare or Applicator.

Accessories

External WLAN antenna mounted on device

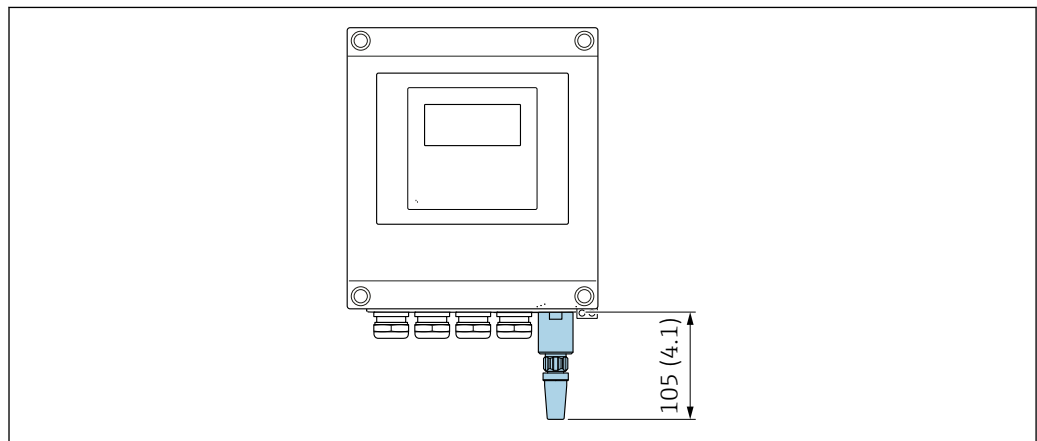

A0033607

45 Engineering unit mm (in)

External WLAN antenna mounted with cable

The external WLAN antenna can be mounted separately from the transmitter if the transmission/reception conditions at the transmitter mounting location are poor.

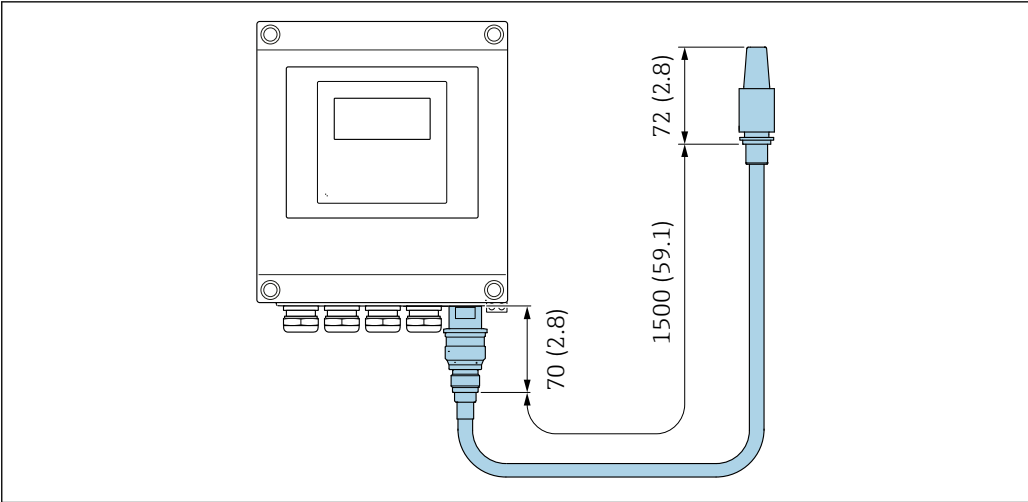

A0033606

46 Engineering unit mm (in)

Dimensions in US units

Transmitter remote version

Order code for "Housing", option N "Remote, polycarbonate" or option P "Remote, aluminum coated"

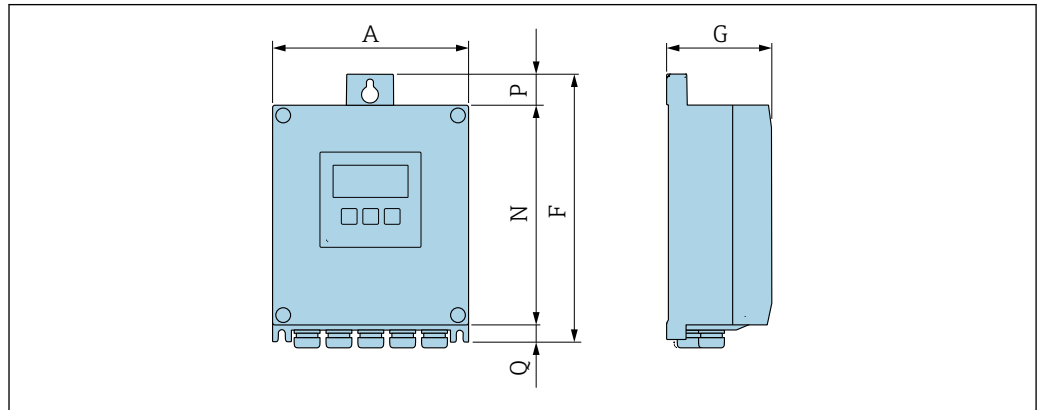

A0033789

Order code for "Transmitter housing", option P "Remote, aluminum, coated"

A [in]	F [in]	G [in]	N [in]	P [in]	Q [in]
6.57	9.13	3.15	7.36	0.94	0.83

Order code for "Transmitter housing", option N "Remote, polycarbonate"

A [in]	F [in]	G [in]	N [in]	P [in]	Q [in]
6.97	9.21	3.54	7.76	0.67	0.87

Sensor remote version

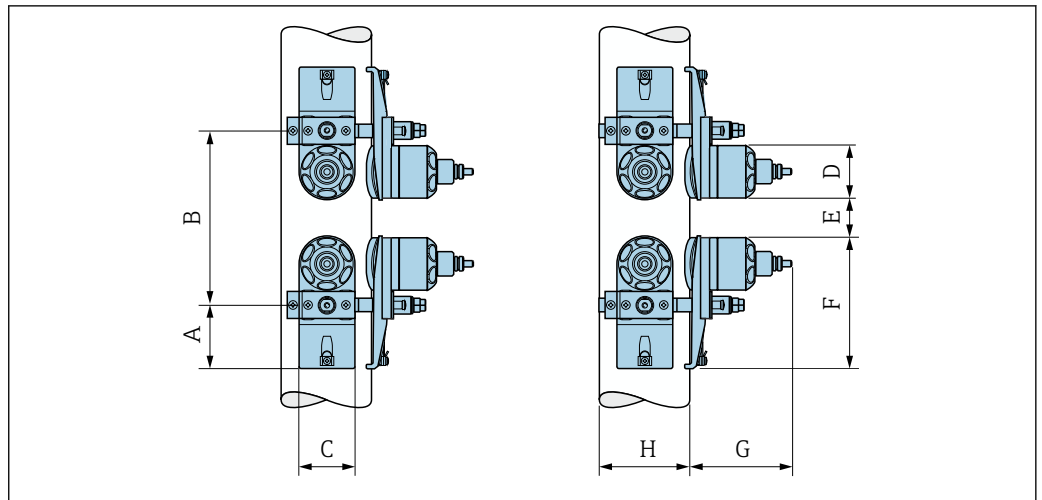

A0041969

47 DN 2 to 160": measurement with 2 sensor sets

A	B	C	D	E _{min}	F	G	H
[in]	[in]	[in]	[in]	[in]	[in]	[in]	[in]
2.20	* 1)	2.44	∅ 2.28	0.20	5.71	4.37	Measuring pipe outer diameter

- 1) Depends on the conditions at the measuring point (measuring pipe, medium etc.). The dimension can be determined via FieldCare or Applicator.

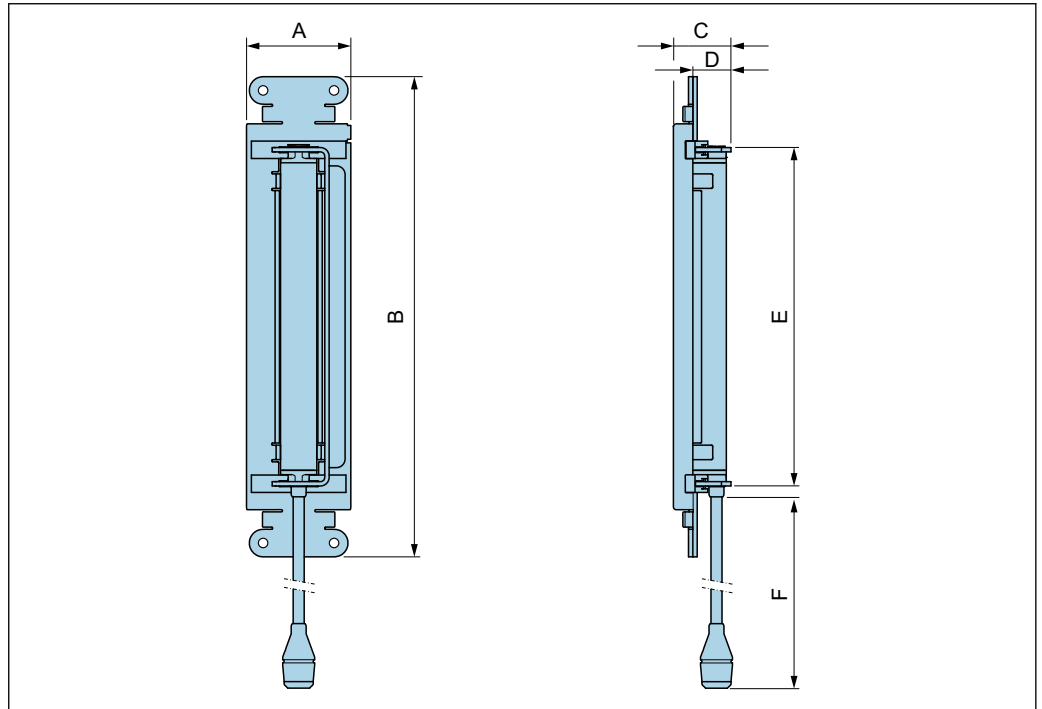

A0041968

48 DN ½ to 2½"

A	B	C	D	E	F
[in]	[in]	[in]	[in]	[in]	[in]
2.83	13.0	1.54	1.10	9.17	17.7

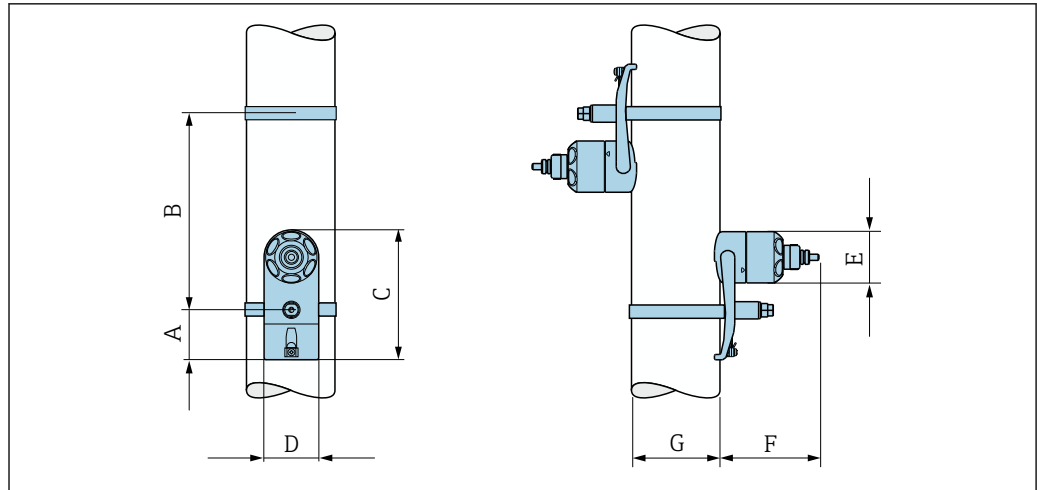

A0041967

49 DN 2 to 160": measurement with 1 sensor set

A	B	C	D	E	F	G
[in]	[in]	[in]	[in]	[in]	[in]	[in]
2.20	* 1)	5.71	2.44	∅ 2.28	4.37	Measuring pipe outer diameter

- 1) Depends on the conditions at the measuring point (measuring pipe, medium etc.). The dimension can be determined via FieldCare or Applicator.

Accessories

External WLAN antenna mounted on device

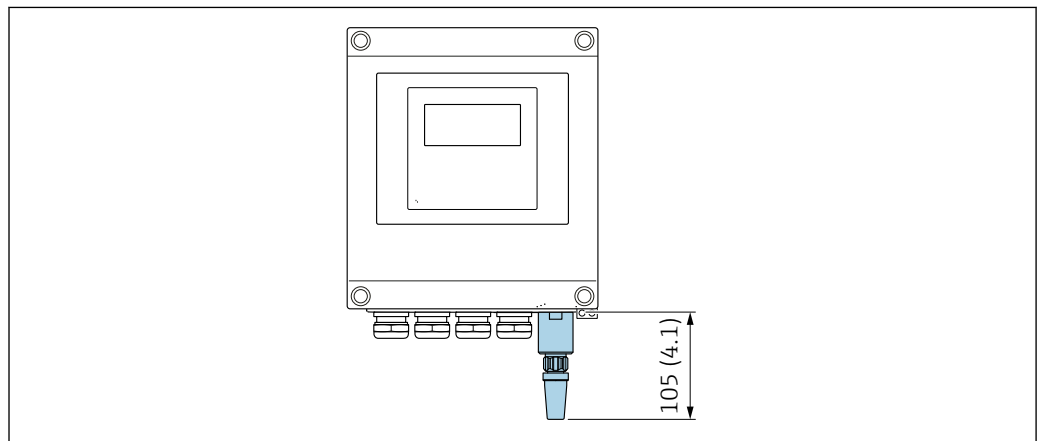

A0033607

50 Engineering unit mm (in)

External WLAN antenna mounted with cable

The external WLAN antenna can be mounted separately from the transmitter if the transmission/reception conditions at the transmitter mounting location are poor.

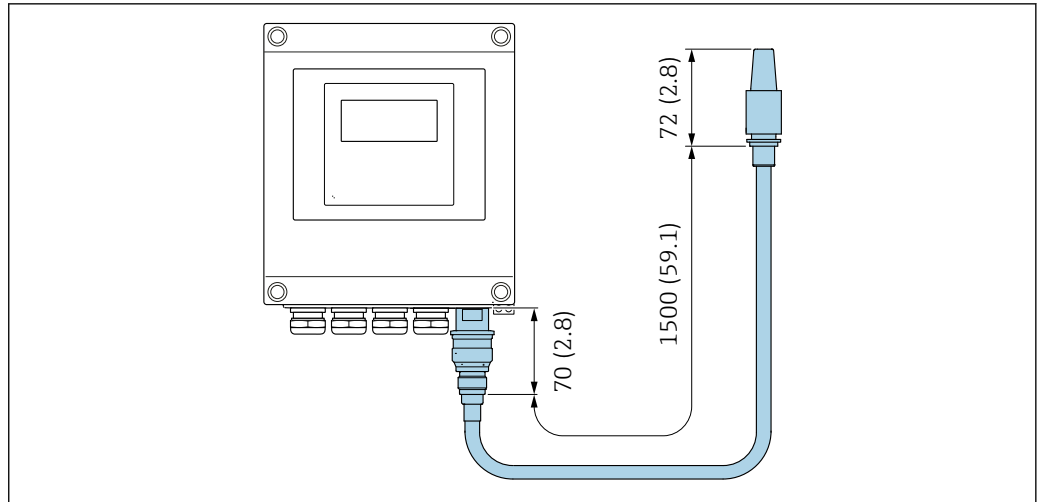

A0033606

51 Engineering unit mm (in)

Weight

Weight specifications excluding packaging material.

Transmitter

- Proline 400 polycarbonate plastic: 1.2 kg (2.65 lb)
- Proline 400 aluminum, coated: 6.0 kg (13.2 lb)

Sensor

Including mounting material

- DN 15 to 65 (½ to 2½"): 1.2 kg (2.65 lb)
- DN 50 to 4000 (2 to 160"): 2.8 kg (6.17 lb)

Materials

Remote version (wall-mount housing)

- Order code for "Housing", option **P** "Remote, alu, coated":
Aluminum, AlSi10Mg, coated
- Order code for "Housing", option **N**: polycarbonate plastic
- Window material:
 - For order code for "Housing", option **P**: glass
 - For order code for "Housing", option **N**: plastic

Cable entries/cable glands

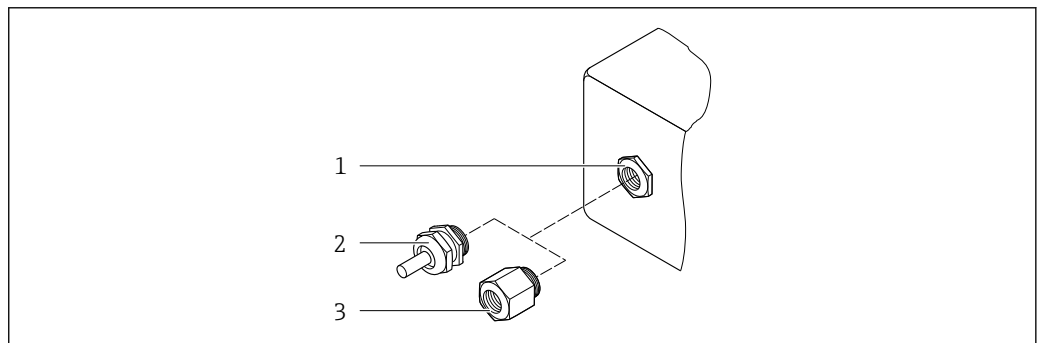

A0020640

52 Possible cable entries/cable glands

- 1 Female thread M20 × 1.5
- 2 Cable gland M20 × 1.5
- 3 Adapter for cable entry with female thread G ½" or NPT ½"

remote version

Cable entry/cable gland	Material
Cable gland M20 × 1.5	<ul style="list-style-type: none"> ■ Plastic ■ Nickel-plated brass
Cable gland of sensor cable	Nickel-plated brass
Power cable gland	Plastic
Adapter for cable entry with female thread G ½" or NPT ½"	Nickel-plated brass

Sensor - transmitter cable

 UV rays can impair the cable outer sheath. Protect the cable from exposure to sun as much as possible.

DN 15 to 65 (½ to 2½"):

Sensor cable: TPE

- Cable sheath: TPE
- Cable plug: nickel-plated brass

DN 50 to 4000 (2 to 160"):

- Sensor cable, TPE halogen-free
 - Cable sheath: TPE halogen-free
 - Cable plug: nickel-plated brass
- Sensor cable PTFE
 - Cable sheath: PTFE
 - Cable plug: stainless steel 1.4301 (304), 1.4404 (316L)

Ultrasonic transducer

- Holder: stainless steel 1.4301 (304), 1.4404 (316L)
- Housing: stainless steel 1.4301 (304), 1.4404 (316L)
- Strapping bands/bracket: stainless steel 1.4301 (304), 1.4404 (316L)
- Contact surfaces: chemically stable plastic

Accessories

External WLAN antenna

- Antenna: ASA plastic (acrylic ester-styrene-acrylonitrile) and nickel-plated brass
- Adapter: Stainless steel and nickel-plated brass
- Cable: Polyethylene
- Plug: Nickel-plated brass
- Angle bracket: Stainless steel

Operability

Operating concept

Operator-oriented menu structure for user-specific tasks

- Commissioning
- Operation
- Diagnostics
- Expert level

Fast and safe commissioning

- Guided menus ("Make-it-run" wizards) for applications
- Menu guidance with brief descriptions of the individual parameter functions
- Access to the device via Web server
- WLAN access to the device via mobile handheld terminal, tablet or smart phone

Reliable operation

- Operation in local language
- Uniform operating philosophy applied to device and operating tools
- If replacing electronic modules, transfer the device configuration via the integrated memory (HistoROM backup) which contains the process and measuring device data and the event logbook. No need to reconfigure.

Efficient diagnostic behavior increases measurement availability

- Troubleshooting measures can be called up via the device and in the operating tools
- Diverse simulation options, logbook for events that occur and optional line recorder functions

Installation quality

To optimize the sensor mounting positions, real-time display of:

- Installation status (good, bad, acceptable)
- Signal strength
- Signal to noise ratio
- Sound velocity

Languages

Can be operated in the following languages:

- Via local operation:
English, German, French, Spanish, Italian, Dutch, Portuguese, Polish, Russian, Turkish, Chinese, Japanese, Bahasa (Indonesian), Vietnamese, Czech, Swedish
- Via "FieldCare", "DeviceCare" operating tool:
English, German, French, Spanish, Italian, Chinese, Japanese
- Via Web browser (only available for device versions with HART, PROFIBUS DP and EtherNet/IP):
English, German, French, Spanish, Italian, Dutch, Portuguese, Polish, Russian, Turkish, Chinese, Japanese, Bahasa (Indonesian), Vietnamese, Czech, Swedish

Local operation

Via display module

Equipment:

- Standard features 4-line, illuminated, graphic display; touch control
- Order code for "Display; operation", option G "4-line, illuminated; Touch Control +WLAN" offers standard equipment features in addition to access via Web browser

 Information about WLAN interface →  50

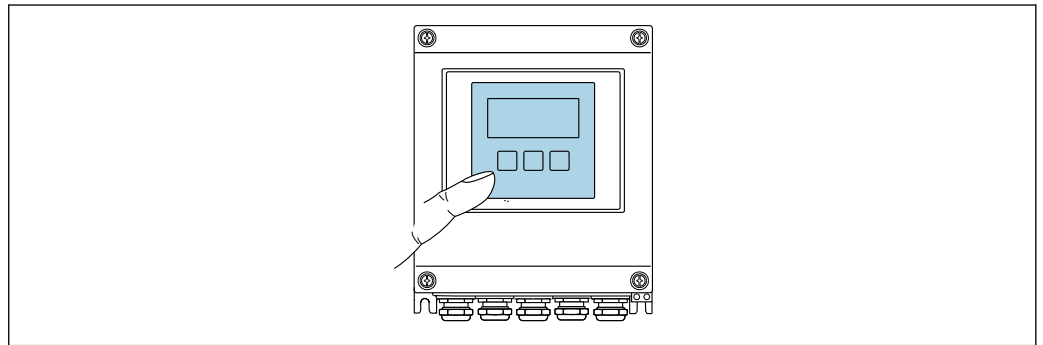

 53 Operation with touch control

Display elements

- 4-line, illuminated, graphic display
- White background lighting; switches to red in event of device errors
- Format for displaying measured variables and status variables can be individually configured
- Permitted ambient temperature for the display: -20 to +60 °C (-4 to +140 °F)
The readability of the display may be impaired at temperatures outside the temperature range.

Operating elements

- External operation via touch control (3 optical keys) without opening the housing: , , 
- Operating elements also accessible in the various zones of the hazardous area

Remote operation

Via HART protocol

This communication interface is available in device versions with a HART output.

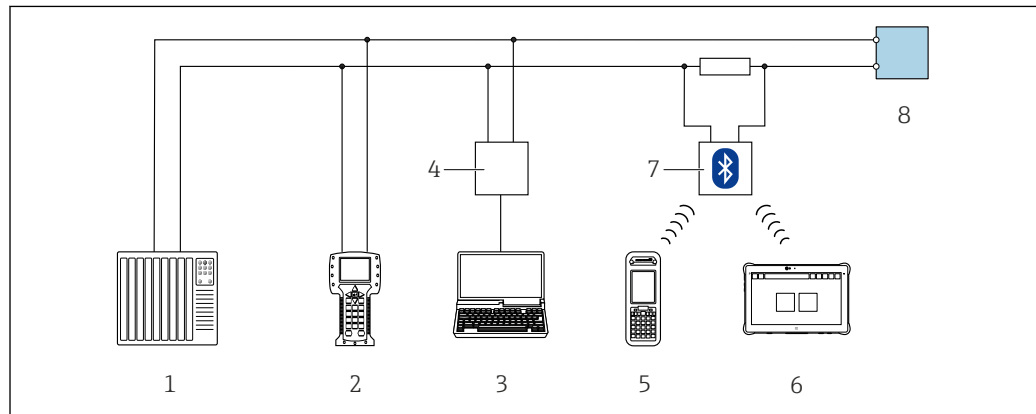

54 Options for remote operation via HART protocol

- 1 Control system (e.g. PLC)
- 2 Field Communicator 475
- 3 Computer with operating tool (e.g. FieldCare, AMS Device Manager, SIMATIC PDM)
- 4 Commubox FXA195 (USB)
- 5 Field Xpert SFX350 or SFX370
- 6 Field Xpert SMT70
- 7 VIATOR Bluetooth modem with connecting cable
- 8 Transmitter

Service interface

Via service interface (CDI-RJ45)

This communication interface is present in the following device version:

- Order code for "Output", option H: 4 to 20 mA HART, pulse/frequency output, switch output
- Order code for "Output", option I: 4 to 20 mA HART, 2 x pulse/frequency/switch output, status input

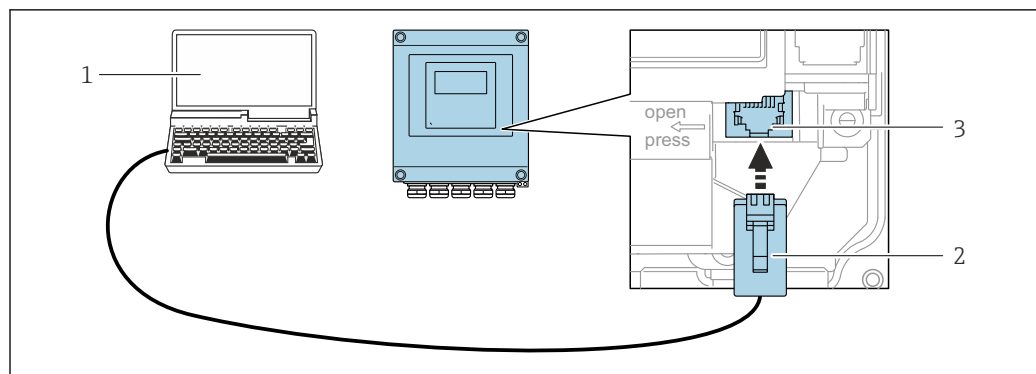

55 Connection via service interface (CDI-RJ45)

- 1 Computer with Web browser (e.g. Microsoft Internet Explorer, Microsoft Edge) for accessing the integrated device Web server or with "FieldCare", "DeviceCare" operating tool with COM DTM "CDI Communication TCP/IP"
- 2 Standard Ethernet connecting cable with RJ45 plug
- 3 Service interface (CDI-RJ45) of the measuring device with access to the integrated Web server

Via WLAN interface

The optional WLAN interface is available on the following device version:

Order code for "Display; operation", option G "4-line, illuminated; touch control + WLAN"

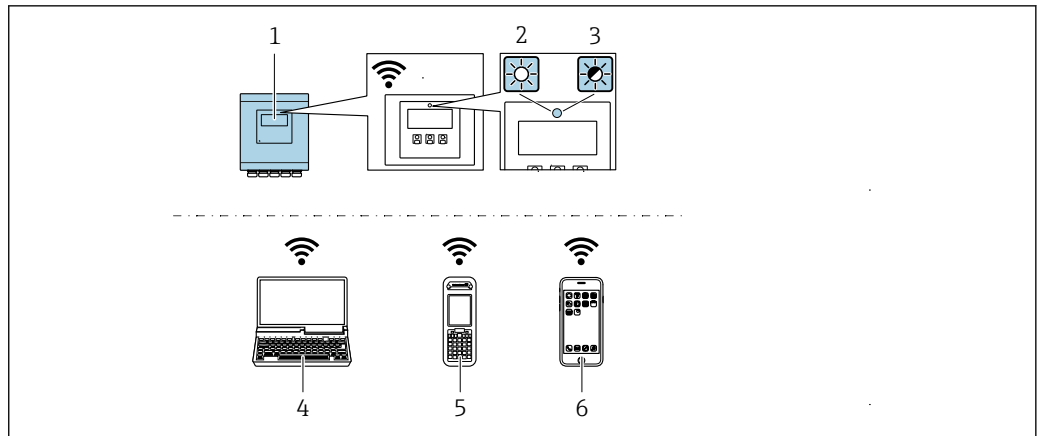

A0043149

- 1 Transmitter with integrated WLAN antenna
- 2 LED lit constantly: WLAN reception is enabled on measuring device
- 3 LED flashing: WLAN connection established between operating unit and measuring device
- 4 Computer with WLAN interface and Web browser (e.g. Microsoft Internet Explorer, Microsoft Edge) for accessing the integrated device Web server or with operating tool (e.g. FieldCare, DeviceCare)
- 5 Mobile handheld terminal with WLAN interface and Web browser (e.g. Microsoft Internet Explorer, Microsoft Edge) for accessing the integrated device Web server or operating tool (e.g. FieldCare, DeviceCare)
- 6 Smart phone or tablet (e.g. Field Xpert SMT70)

Function	WLAN: IEEE 802.11 b/g (2.4 GHz) <ul style="list-style-type: none"> ■ Access point with DHCP server (default setting) ■ Network
Encryption	WPA2-PSK AES-128 (in accordance with IEEE 802.11i)
Configurable WLAN channels	1 to 11
Degree of protection	IP67
Available antenna	Internal antenna
Range	Typically 10 m (32 ft)

Supported operating tools

Different operating tools can be used for local or remote access to the measuring device. Depending on the operating tool used, access is possible with different operating units and via a variety of interfaces.

Supported operating tools	Operating unit	Interface	Additional information
Web browser	Notebook, PC or tablet with Web browser	<ul style="list-style-type: none"> ■ CDI-RJ45 service interface ■ WLAN interface 	Special Documentation for the device
DeviceCare SFE100	Notebook, PC or tablet with Microsoft Windows system	<ul style="list-style-type: none"> ■ CDI-RJ45 service interface ■ WLAN interface ■ Fieldbus protocol 	→ 58

Supported operating tools	Operating unit	Interface	Additional information
FieldCare SFE500	Notebook, PC or tablet with Microsoft Windows system	<ul style="list-style-type: none"> ■ CDI-RJ45 service interface ■ WLAN interface ■ Fieldbus protocol 	→  58
Device Xpert	Field Xpert SFX 100/350/370	Fieldbus protocol HART	Operating Instructions BA01202S Device description files: Use update function of handheld terminal

 Other operating tools based on FDT technology with a device driver such as DTM/iDTM or DD/EDD can be used for device operation. These operating tools are available from the individual manufacturers. Integration into the following operating tools, among others, is supported:

- FactoryTalk AssetCentre (FTAC) from Rockwell Automation → www.rockwellautomation.com
- Process Device Manager (PDM) from Siemens → www.siemens.com
- Asset Management Solutions (AMS) from Emerson → www.emersonprocess.com
- FieldCommunicator 375/475 from Emerson → www.emersonprocess.com
- Field Device Manager (FDM) from Honeywell → www.honeywellprocess.com
- FieldMate from Yokogawa → www.yokogawa.com
- PACTWare → www.pactware.com

The related device description files are available: www.endress.com → Downloads

Web server

Thanks to the integrated Web server the device can be operated and configured via a Web browser and via a standard Ethernet switch (RJ45) or via a WLAN interface. The structure of the operating menu is the same as the menu on the local display. In addition to the measured values, status information about the device is also displayed and allows the user to monitor the status of the device. Furthermore the device data can be managed and the network parameters can be configured.

A device that has a WLAN interface (can be ordered as an option) is required for the WLAN connection: order code for "Display", option G "4-line, illuminated; Touch Control +WLAN". The device acts as an Access Point and enables communication by computer or a mobile handheld terminal.

Supported functions

Data exchange between the operating unit (such as a notebook for example) and the measuring device:

- Upload the configuration from the measuring device (XML format, create configuration back-up)
- Save the configuration to the measuring device (XML format, restore configuration)
- Export event list (.csv file)
- Export parameter settings (.csv file or PDF file, document the measuring point configuration)
- Export the Heartbeat verification log (PDF file, only available with the "Heartbeat Verification" application package)
- Flash firmware version for device firmware upgrade, for instance
- Download driver for system integration
- Display up to 1000 saved measured values (only available with the **Extended HistoROM** application package →  55)



Web server special documentation

HistoROM data management

The measuring device features HistoROM data management. HistoROM data management comprises both the storage and import/export of key device and process data, making operation and servicing far more reliable, secure and efficient.

Additional information on the data storage concept

There are different types of data storage units in which device data are stored and used by the device:

	HistoROM backup	T-DAT	S-DAT
Available data	<ul style="list-style-type: none"> Event logbook such as diagnostic events for example Device firmware package 	<ul style="list-style-type: none"> Measured value logging ("Extended HistoROM" order option) Current parameter data record (used by firmware at run time) Peakhold indicator (min/max values) Totalizer values 	<ul style="list-style-type: none"> Sensor data: etc. Serial number Device configuration (e.g. SW options, fixed I/O or multi I/O)
Storage location	Fixed on the user interface board in the connection compartment	Attachable to the user interface board in the connection compartment	Fixed on the sensor connection board

Data backup

Automatic

- The most important device data (sensor and transmitter) are automatically saved in the DAT modules
- If the transmitter or measuring device is replaced: once the T-DAT containing the previous device data has been exchanged, the new measuring device is ready for operation again immediately without any errors
- If the sensor is replaced: once the sensor has been replaced, new sensor data are transferred from the S-DAT in the measuring device and the measuring device is ready for operation again immediately without any errors

Data transmission

Manual

Transfer of a device configuration to another device using the export function of the specific operating tool, e.g. with FieldCare, DeviceCare or Web server: to duplicate the configuration or to store in an archive (e.g. for backup purposes)

Event list

Automatic

- Chronological display of up to 20 event messages in the events list
- If the **Extended HistoROM** application package (order option) is enabled: up to 100 event messages are displayed in the events list along with a time stamp, plain text description and remedial measures
- The events list can be exported and displayed via a variety of interfaces and operating tools e.g. DeviceCare, FieldCare or Web server

Data logging

Manual

If the **Extended HistoROM** application package (order option) is enabled:



- Record up to 1 000 measured values via 1 to 4 channels
- User configurable recording interval
- Record up to 250 measured values via each of the 4 memory channels
- Export the measured value log via a variety of interfaces and operating tools e.g. FieldCare, DeviceCare or web server

Certificates and approvals

Current certificates and approvals for the product are available via the Product Configurator at www.endress.com.

- Select the product using the filters and search field.
- Open the product page.

The **Configuration** button opens the Product Configurator.

CE mark	<p>The device meets the legal requirements of the applicable EU Directives. These are listed in the corresponding EU Declaration of Conformity along with the standards applied.</p> <p>Endress+Hauser confirms successful testing of the device by affixing to it the CE mark.</p>
UKCA marking	<p>The device meets the legal requirements of the applicable UK regulations (Statutory Instruments). These are listed in the UKCA Declaration of Conformity along with the designated standards. By selecting the order option for UKCA marking, Endress+Hauser confirms a successful evaluation and testing of the device by affixing the UKCA mark.</p> <p>Contact address Endress+Hauser UK: Endress+Hauser Ltd. Floats Road Manchester M23 9NF United Kingdom www.uk.endress.com</p>
RCM mark	<p>The measuring system meets the EMC requirements of the "Australian Communications and Media Authority (ACMA)".</p>
Ex approval	<p>The devices are certified for use in hazardous areas and the relevant safety instructions are provided in the separate "Control Drawing" document. Reference is made to this document on the nameplate.</p>
HART certification	<p>HART interface</p> <p>The measuring device is certified and registered by the FieldComm Group. The measuring system meets all the requirements of the following specifications:</p> <ul style="list-style-type: none"> ■ Certified according to HART 7 ■ The device can also be operated with certified devices of other manufacturers (interoperability)
Radio approval	<p>The measuring device has radio approval.</p> <p> For detailed information regarding radio approval, see the Special Documentation →  60</p>
Other standards and guidelines	<ul style="list-style-type: none"> ■ EN 60529 Degrees of protection provided by enclosures (IP code) ■ EN 61010-1 Safety requirements for electrical equipment for measurement, control and laboratory use - general requirements ■ IEC/EN 61326-2-3 Emission in accordance with Class A requirements. Electromagnetic compatibility (EMC requirements). ■ ANSI/ISA-61010-1 (82.02.01) Safety Requirements for Electrical Equipment for Measurement, Control and Laboratory Use - Part 1 General Requirements ■ CAN/CSA-C22.2 No. 61010-1-12 Safety Requirements for Electrical Equipment for Measurement, Control and Laboratory Use - Part 1 General Requirements ■ NAMUR NE 32 Data retention in the event of a power failure in field and control instruments with microprocessors ■ NAMUR NE 43 Standardization of the signal level for the breakdown information of digital transmitters with analog output signal. ■ NAMUR NE 53 Software of field devices and signal-processing devices with digital electronics ■ NAMUR NE 105 Specifications for integrating fieldbus devices in engineering tools for field devices ■ NAMUR NE 107 Self-monitoring and diagnosis of field devices ■ NAMUR NE 131 Requirements for field devices for standard applications

Ordering information

Detailed ordering information is available for your nearest sales organization www.addresses.endress.com or in the Product Configurator under www.endress.com :

1. Click Corporate
2. Select the country
3. Click Products
4. Select the product using the filters and search field
5. Open the product page

The Configuration button to the right of the product image opens the Product Configurator.



Product Configurator - the tool for individual product configuration

- Up-to-the-minute configuration data
- Depending on the device: Direct input of measuring point-specific information such as measuring range or operating language
- Automatic verification of exclusion criteria
- Automatic creation of the order code and its breakdown in PDF or Excel output format
- Ability to order directly in the Endress+Hauser Online Shop

Application packages

Many different application packages are available to enhance the functionality of the device. Such packages might be needed to address safety aspects or specific application requirements.

The application packages can be ordered with the device or subsequently from Endress+Hauser. Detailed information on the order code in question is available from your local Endress+Hauser sales center or on the product page of the Endress+Hauser website: www.endress.com.



Detailed information on the application packages:
Special Documentation for the device → 60

Diagnostics functions

Package	Description
Extended HistoROM	<p>Comprises extended functions concerning the event log and the activation of the measured value memory.</p> <p>Event log: Memory volume is extended from 20 message entries (standard version) to up to 100 entries.</p> <p>Data logging (line recorder):</p> <ul style="list-style-type: none"> ■ Memory capacity for up to 1000 measured values is activated. ■ 250 measured values can be output via each of the 4 memory channels. The recording interval can be defined and configured by the user. ■ Measured value logs can be accessed via the local display or operating tool e.g. FieldCare, DeviceCare or Web server.

Heartbeat Technology

Package	Description
Heartbeat Verification +Monitoring	<p>Heartbeat Verification Meets the requirement for traceable verification to DIN ISO 9001:2008 Chapter 7.6 a) "Control of monitoring and measuring equipment".</p> <ul style="list-style-type: none"> ■ Functional testing in the installed state without interrupting the process. ■ Traceable verification results on request, including a report. ■ Simple testing process via local operation or other operating interfaces. ■ Clear measuring point assessment (pass/fail) with high test coverage within the framework of manufacturer specifications. ■ Extension of calibration intervals according to operator's risk assessment. <p>Heartbeat Monitoring Continuously supplies data, which are characteristic of the measuring principle, to an external condition monitoring system for the purpose of preventive maintenance or process analysis. These data enable the operator to:</p> <ul style="list-style-type: none"> ■ Draw conclusions - using these data and other information - about the impact the measuring application has on the measuring performance over time. ■ Schedule servicing in time. ■ Monitor the process or product quality, e.g. gas pockets.

FlowDC





Package	Description
FlowDC	Flow disturbance compensation Shortens the necessary inlet run while maintaining the specified accuracy.

Accessories

Various accessories, which can be ordered with the device or subsequently from Endress+Hauser, are available for the device. Detailed information on the order code in question is available from your local Endress+Hauser sales center or on the product page of the Endress+Hauser website: www.endress.com.

Device-specific accessories**For the transmitter**



Accessories	Description
Transmitter Prosonic Flow 400	<p>Transmitter for replacement or storage. Use the order code to define the following specifications:</p> <ul style="list-style-type: none"> ■ Approvals ■ Output / input ■ Display/operation ■ Housing ■ Software <p> For details, see Installation Instructions EA00104D</p>
Post mounting kit	Post mounting kit for transmitter.





External WLAN antenna	<p>External WLAN antenna with 1.5 m (59.1 in) connecting cable and two angle brackets. Order code for "Accessory enclosed", option P8 "Wireless antenna wide area".</p> <ul style="list-style-type: none">  The external WLAN antenna is not suitable for use in hygienic applications. Additional information regarding the WLAN interface →  50. <p> Order number: 71351317</p> <p> Installation Instructions EA01238D</p>
Sensor cable Proline 400 Sensor – transmitter	<p>The sensor cable can be ordered directly with the measuring device (order code for "Cable") or as an accessory (order number DK9017).</p> <p>The following cable lengths are available:</p> <ul style="list-style-type: none"> Temperature: -40 to +80 °C (-40 to +176 °F) <ul style="list-style-type: none"> Option AA: 5 m (15 ft) Option AB: 10 m (30 ft) Option AC: 15 m (45 ft) Option AD: 30 m (90 ft) Temperature: -40 to +130 °C (-40 to +266 °F) <ul style="list-style-type: none"> Option FA: 5 m (15 ft) Option FB: 10 m (30 ft) Option FC: 15 m (45 ft) Option FD: 30 m (90 ft) <p> Possible cable length for a Proline 400 sensor cable: Max. 30 m (90 ft)</p>

For the sensor

Accessories	Description
Sensor set (DK9018)	<ul style="list-style-type: none"> Sensor set 0.3 MHz (C-030) Sensor set 0.5 MHz (C-050) Sensor set 1 MHz (C-100) Sensor set 2 MHz (C-200) Sensor set 5 MHz (C-500)
Sensor holder set (DK9014)	<ul style="list-style-type: none"> Sensor holder set 0.3 to 2 MHz Sensor holder set 5 MHz
Installation set (DK9015)	<ul style="list-style-type: none"> Installation set, DN15-DN32, 1/2-1 1/4" Installation set, DN32-DN65, 1 1/2-2 1/2" Installation set, DN50-DN150, 2"-6" Installation set, DN150-DN200, 6"-8" Installation set, DN200-DN600, 8"-24" Installation set, DN600-DN2000, 24"-80" Installation set, DN2000-DN4000, 80"-160"
Conduit adapter set (DK9003)	<ul style="list-style-type: none"> Without conduit adapter + sensor cable gland Conduit adapter M20x1.5 + sensor cable gland Conduit adapter NPT1/2" + sensor cable gland Conduit adapter G1/2" + sensor cable gland
Coupling medium (DK9CM)	<ul style="list-style-type: none"> Permanent coupling pad Coupling gel



Communication-specific accessories

Accessories	Description
Commubox FXA195 HART	<p>For intrinsically safe HART communication with FieldCare via the USB interface.</p> <p> Technical Information TI00404F</p>
Commubox FXA291	<p>Connects Endress+Hauser field devices with a CDI interface (= Endress+Hauser Common Data Interface) and the USB port of a computer or laptop.</p> <p> Technical Information TI405C/07</p>

HART Loop Converter HMX50	<p>Is used to evaluate and convert dynamic HART process variables to analog current signals or limit values.</p> <ul style="list-style-type: none">  <ul style="list-style-type: none"> ▪ Technical Information TI00429F ▪ Operating Instructions BA00371F
Wireless HART adapter SWA70	<p>Is used for the wireless connection of field devices. The WirelessHART adapter can be easily integrated into field devices and existing infrastructures, offers data protection and transmission safety and can be operated in parallel with other wireless networks with minimum cabling complexity.</p> <ul style="list-style-type: none">  <ul style="list-style-type: none"> ▪ Operating Instructions BA00061S
Fieldgate FXA42	<p>Is used to transmit the measured values of connected 4 to 20 mA analog measuring devices, as well as digital measuring devices</p> <ul style="list-style-type: none">  <ul style="list-style-type: none"> ▪ Technical Information TI01297S ▪ Operating Instructions BA01778S ▪ Product page: www.endress.com/fxa42
Field Xpert SMT70	<p>The Field Xpert SMT70 tablet PC for device configuration enables mobile plant asset management in hazardous and non-hazardous areas. It is suitable for commissioning and maintenance staff to manage field instruments with a digital communication interface and to record progress. This tablet PC is designed as an all-in-one solution with a preinstalled driver library and is an easy-to-use, touch-sensitive tool which can be used to manage field instruments throughout their entire life cycle.</p> <ul style="list-style-type: none">  <ul style="list-style-type: none"> ▪ Technical Information TI01342S ▪ Operating Instructions BA01709S ▪ Product page: www.endress.com/smt70
Field Xpert SMT77	<p>The Field Xpert SMT77 tablet PC for device configuration enables mobile plant asset management in areas categorized as Ex Zone 1.</p> <ul style="list-style-type: none">  <ul style="list-style-type: none"> ▪ Technical Information TI01418S ▪ Operating Instructions BA01923S ▪ Product page: www.endress.com/smt77

Service-specific accessories

Accessory	Description
Applicator	<p>Software for selecting and sizing Endress+Hauser measuring devices:</p> <ul style="list-style-type: none"> ▪ Choice of measuring devices with industrial requirements ▪ Calculation of all the necessary data for identifying the optimum flowmeter: e.g. nominal diameter, pressure loss, flow velocity and accuracy. ▪ Graphic illustration of the calculation results ▪ Determination of the partial order code, administration, documentation and access to all project-related data and parameters over the entire life cycle of a project. <p>Applicator is available:</p> <ul style="list-style-type: none"> ▪ Via the Internet: https://portal.endress.com/webapp/applicator ▪ As a downloadable DVD for local PC installation.
W@M	<p>W@M Life Cycle Management</p> <p>Improved productivity with information at your fingertips. Data relevant to a plant and its components is generated from the first stages of planning and during the asset's complete life cycle.</p> <p>W@M Life Cycle Management is an open and flexible information platform with online and on-site tools. Instant access for your staff to current, in-depth data shortens your plant's engineering time, speeds up procurement processes and increases plant uptime.</p> <p>Combined with the right services, W@M Life Cycle Management boosts productivity in every phase. For more information, see: www.endress.com/lifecyclemanagement</p>

Accessory	Description
FieldCare	FDT-based plant asset management tool from Endress+Hauser. It can configure all smart field units in your system and helps you manage them. By using the status information, it is also a simple but effective way of checking their status and condition.  Operating Instructions BA00027S and BA00059S
DeviceCare	Tool for connecting and configuring Endress+Hauser field devices.  Innovation brochure IN01047S

System components

Accessories	Description
Memograph M graphic data manager	The Memograph M graphic data manager provides information on all the relevant measured variables. Measured values are recorded correctly, limit values are monitored and measuring points analyzed. The data are stored in the 256 MB internal memory and also on a SD card or USB stick.  <ul style="list-style-type: none"> ▪ Technical Information TI00133R ▪ Operating Instructions BA00247R

Documentation

-  For an overview of the scope of the associated Technical Documentation, refer to the following:
- *W@M Device Viewer* (www.endress.com/deviceviewer): Enter the serial number from the nameplate
 - *Endress+Hauser Operations App*: Enter the serial number from the nameplate or scan the matrix code on the nameplate

Standard documentation

Brief Operating Instructions

Brief Operating Instructions for the sensor

Measuring device	Documentation code
Proline Prosonic Flow W	KA01512D

Brief Operating Instructions for the transmitter

Measuring device	Documentation code
Proline 400	KA01510D

Operating Instructions

Measuring device	Documentation code
Prosonic Flow W 400	BA02086D

Description of device parameters

Measuring device	Documentation code
Prosonic Flow W 400	GP01167D

**Supplementary device-
dependent documentation** **Special Documentation**

Contents	Documentation code
	HART
Radio approvals for WLAN interface for A309/A310 display module	SD01793D
FlowDC	SD02691D
Heartbeat Technology	SD02712D
Web server	SD02713D

Installation Instructions

Content	Comment
Installation instructions for spare part sets and accessories	Documentation code: specified for each individual accessory → 56.

Registered trademarks**HART®**

Registered trademark of the FieldComm Group, Austin, USA



71542320

www.addresses.endress.com