

Data Sheet

shhark[®]

Compact Multiple and shhark[®] Pump

Danfoss has developed the compact multiple pump in standard and shhark[®] version in order to meet the requirements of compactness and low noise emission in one solution.

This configuration also has 120 Nm as maximum torque by stages, so that it is possible to work concurrently at high pressure with large displacements.

Advantages

- **Thanks to compact design: easy installation and machine design flexibility** - compact dimensions of the pump
- **High working performance** - higher torque transmission compared to other standard multiple pumps
- **Thanks to shhark[®] design: cost saving** - secondary noise reduction measures eliminated
- **Improved operator comfort** - better sound quality compared to other low noise technologies on the market
- **Noise regulation compliance** - helps meet legal NVH (noise, vibration, harshness) requirements
- **Recommended for electric machines**

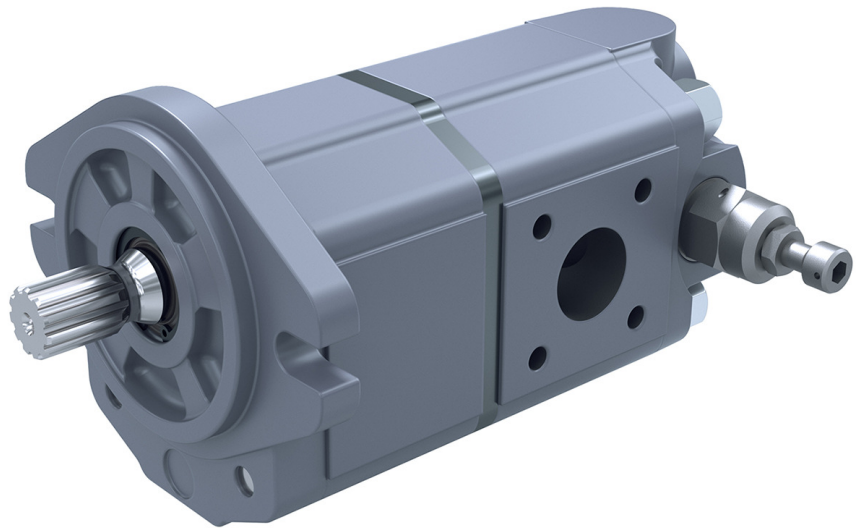

Features

Configurations available

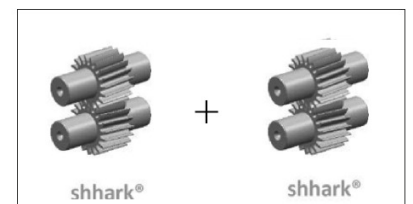
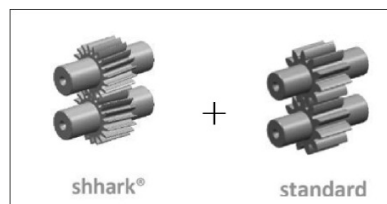
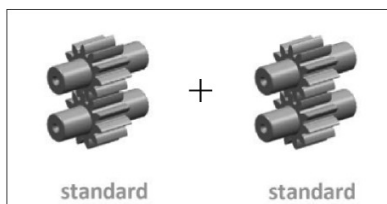

Comprehensive technical literature is online at www.danfoss.com

Noise level @ 3000 rpm 50°C

Sound pressure [dB(A)]

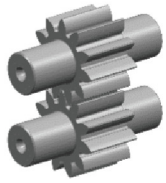

standard

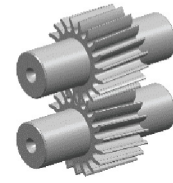
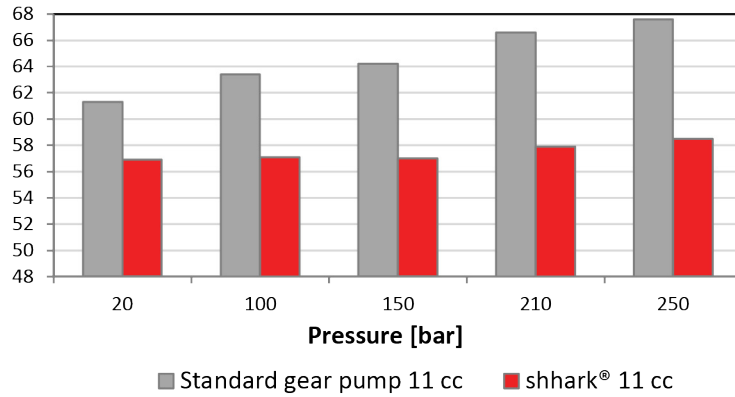

shhark®

Dimensions

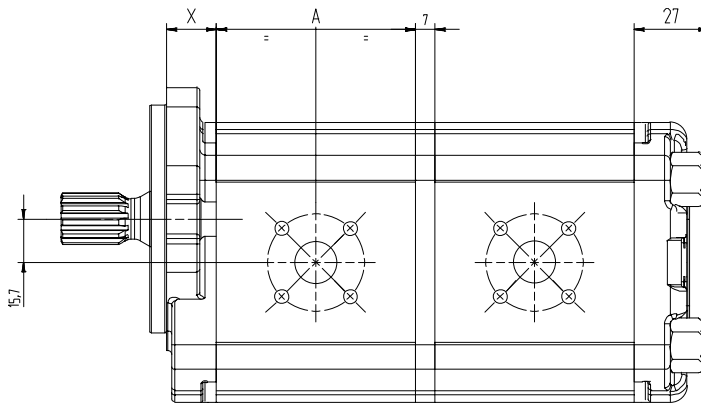

Design	Frame size	4.0	6.0	8.0	011	014	017	019	022	025
Compact	Dimension A	50.5	54	58	62	68	72	76	82	86
Ultracompact*	Dimension A	40.5	44	48	52	58	62	66	72	76

* Pressure limitations; please contact your sales representative for more information

Mounting flange (X)

E10	European 4 bolts pilot Ø36.5	18
B10	German 4 bolts pilot Ø80	20.5
B20	German 2-bolt (\ mounting holes pattern) pilot Ø50	18
B22	German 2-bolt (/ mounting holes pattern) pilot Ø50	18
SA1	SAE-A 2 bolts pilot Ø82.55	18
SA2	SAE-A 2 bolts pilot Ø82.55 + Oring on pilot	18
SB1	SAE-B 2 bolts pilot Ø101.6	22

Main applications

Tractors, wheel loaders, telehandlers, sweepers, rollers, combines and harvesters, excavators, cab equipped mobile machines

Danfoss can accept no responsibility for possible errors in catalogues, brochures and other printed material. Danfoss reserves the right to alter its products without notice. This also applies to products already on order provided that such alterations can be made without subsequent changes being necessary in specifications already agreed. All trademarks in this material are property of the respective companies. Danfoss and the Danfoss logotype are trademarks of Danfoss A/S. All rights reserved.