

Technical Information

OUSA22

Optical sensor combined with the OUA260 flow assembly for the measurement of color concentrations



Application

The sensor is used to measure color concentrations in the range of the visible electromagnetic spectrum.

- Color scale measurement
 - APHA/Hazen, EBC, ASBC, ASTM, ICUMSA
- Measurement of color concentration
 - Outgoing goods inspection/purity monitoring
 - Color assurance
 - Discoloration control
 - Distillation monitoring

Your benefits

- As slightest color changes are detected, production quality is guaranteed
 - Measuring range up to 2.5 AU or 50 OD (depending on optical path length)
 - Can be configured to measure color concentration at discrete wavelengths in the visible region
 - Outstanding filter properties for highest linearity
 - Direct concurrence with laboratory values
 - Integrated reference detector for the compensation of particles, bubbles and lamp aging
- Incandescent lamp for long service life and stable measured values
- Cost-effective, time-efficient verification (liquid-free)
- FM- and ATEX-approved lamps for applications in the hazardous area
- Deployable and durable in numerous applications:
 - Variety of materials and process connections
- Hygienic design for high degree of product safety: certified materials and CIP/SIP-resistance
- Can be adapted to process requirements:
 - Optional air purge ports to prevent the formation of condensate on the optical windows

Function and system design

Measuring principle

Light absorption

The measuring principle is based on the Lambert-Beer law.

There is a linear dependency between the absorption of light and the concentration of the absorbing substance:

$$A = -\log A_m = \epsilon \cdot c \cdot OPL$$

A ... absorption, A_m ... absorption measured by detector

ϵ ... Extinction coefficient

c ... Concentration

OPL ... Optical path length

A light source emits radiation through the medium and the incident radiation is measured on the detector side.

A beam splitter splits the light into two beams. One beam is used for measuring while the other acts as a reference to compensate for particles, bubbles and lamp aging.

Once the light has passed through a filter for wavelength selection, the intensity of the light is determined by a photodiode and converted to a photocurrent.

The subsequent conversion to absorbance units (AU, OD) is performed in the associated transmitter.

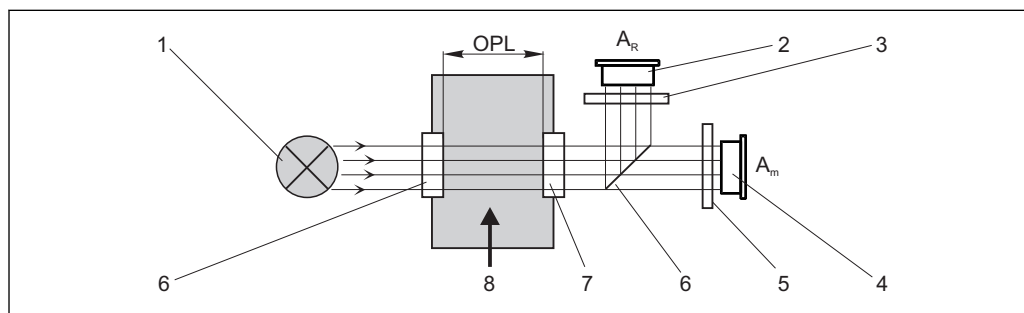

1 Absorption measurement (double wavelength) with reference

- 1 Light source
- 2 Reference detector
- 3 Reference filter
- 4 Measuring detector
- 5 Measurement filter
- 6 Beam splitter
- 7 Optical windows
- 8 Medium flow

Measuring system

An optical measuring system comprises:

- Sensor (photometer) OUSAf22
- Liquiline CM44P transmitter
- Cable set CUK80
- Assembly to suit the sensor, e.g. OUA260

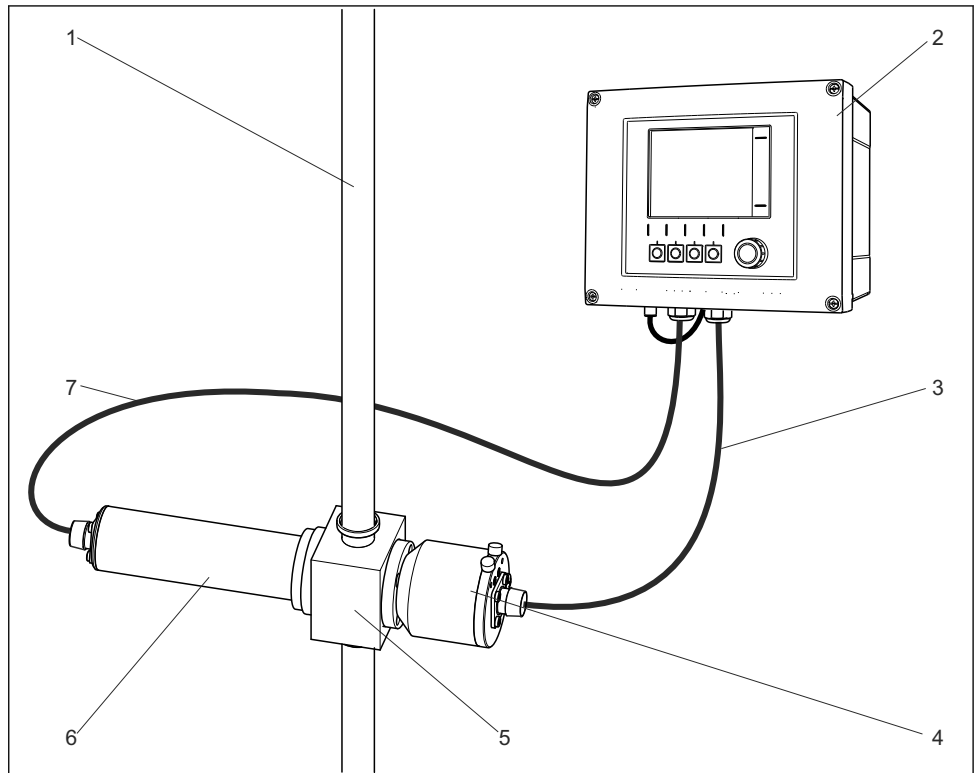

2 Example of a measuring system with a photometer sensor

1	pipe	5	Flow assembly OUA260
2	Transmitter CM44P	6	Sensor: light source (lamp)
3	Cable set CUK80	7	Cable set CUK80
4	Sensor: detector		

Input

Measured variable	process absorption
Measuring range	<ul style="list-style-type: none"> ■ 0 to 2.5 AU ■ Max. 50 OD (depending on the optical path length)
Wavelength	Measurement 400 nm, 420 nm, 430 nm, 490 nm, 520 nm Reference 720 nm

Power supply

Electrical connection	The sensor is connected to the transmitter using the pre-terminated or labeled cable set CUK80 (for connection to CM44P) or OUK20 (for connection to CVM40). The terminals and labeling may vary depending on the transmitter in use. The cable set must be ordered separately.
------------------------------	---

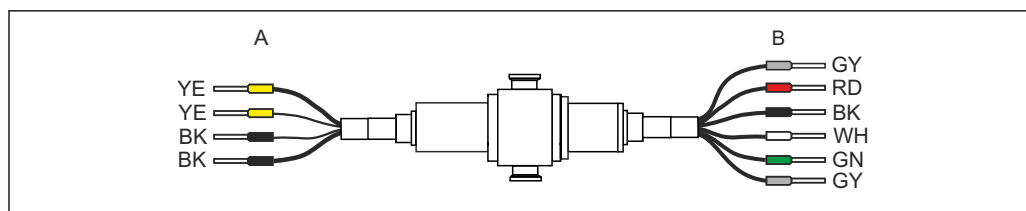

A0028384

3 OUSAF22 connecting cable

A Light source (lamp) power supply

B Signals of measurement and reference detector

CM44P terminal	CVM40 terminal	Cable color	Assignment
P+	V1.1	YE (thick)	Lamp voltage +
S+	V1.3	YE (thin)	Detection of lamp voltage +
P-	V1.2	BK (thick)	Lamp voltage -
S-	V1.4	BK (thin)	Detection of lamp voltage -
A (1)	S1.1	RD	Measuring detector sensor +
C(1)	S1.2	BK	Measuring detector sensor -
SH (1)	S1.S	GY	Shield
A (2)	S2.1	WH	Sensor reference +
C(2)	S2.2	GN	Sensor reference -
SH (2)	S2.S	GY	Shield

Cable length Maximum 100 m (330 ft)

Lamp voltage

Sensor version	Lamp type	Lamp voltage [V]
OUSAF22-xxxxx	Dual beam, high-luminescence or gas-filled high-performance lamp	4.9 ± 0.1

Versions for use in hazardous areas

 Safety instructions for electrical apparatus in explosion-hazardous areas, XA01403C

Connecting the detector using a safety barrier

The photometer sensors use silicon photovoltaic cells as detectors which are operated in the current mode. The detectors are intrinsically safe and can be deployed in Zone 1 environments.

The safe area is separated from the hazardous area by two safety barriers MTL7760AC.

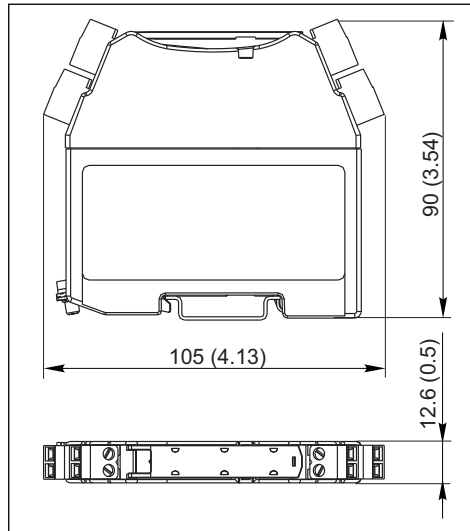

4 Safety barrier, dimensions in mm (inch)

i The safety barrier may only have a very low leak current since the optical signals from the sensor can be in the nanoampere range. Therefore, the sensor cable shield is connected to the ground terminal of the barrier.

On delivery, the CUK80 detector cable is permanently wired to the safety barriers. All you have to do is simply connect the individual cable ends to the detector and transmitter.

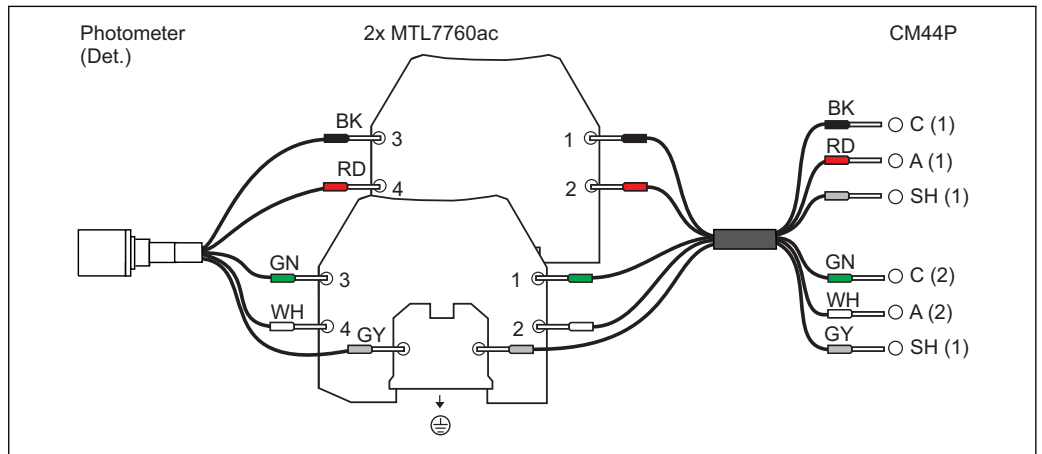

Connecting the hazardous area lamp using a junction box

The hazardous area lamp (EXP-1) must be connected to the transmitter using a certified junction box.

i For versions with FM approval, the junction box is included in the delivery and already pre-terminated on the lamp side. You simply have to connect the cable of the transmitter (CUK80) to the terminals of the junction box.

For versions with ATEX approval, the junction box is not included in the delivery and it and the cable glands required must be provided by the customer at the place of installation. You must connect the cables entirely on your own (CUK80 of transmitter and lamp cable of photometer sensor).

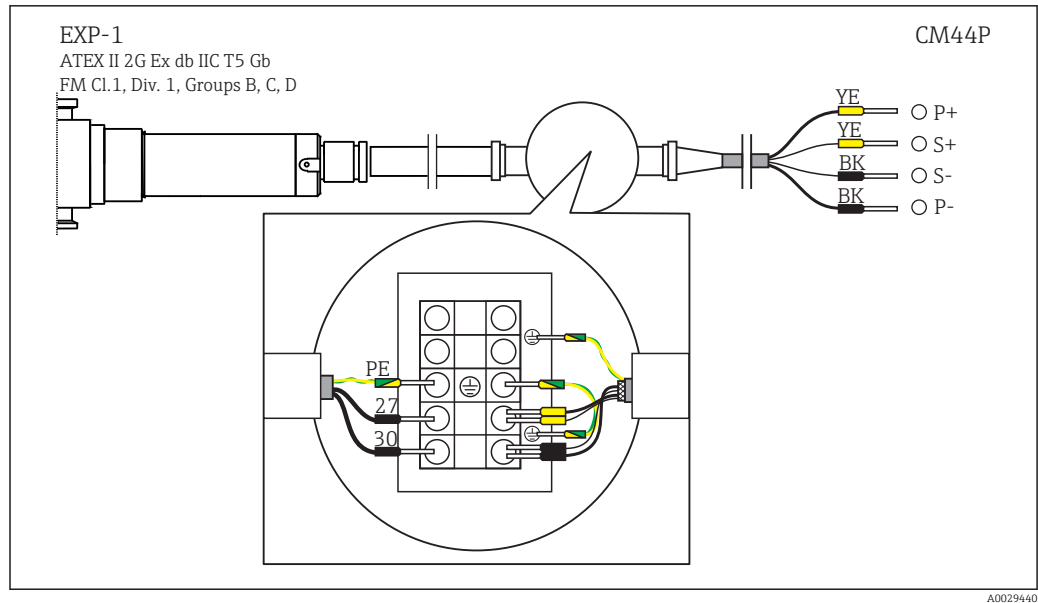

5 Connecting the hazardous area lamp to CM44P using a junction box

Installation

Installation instructions

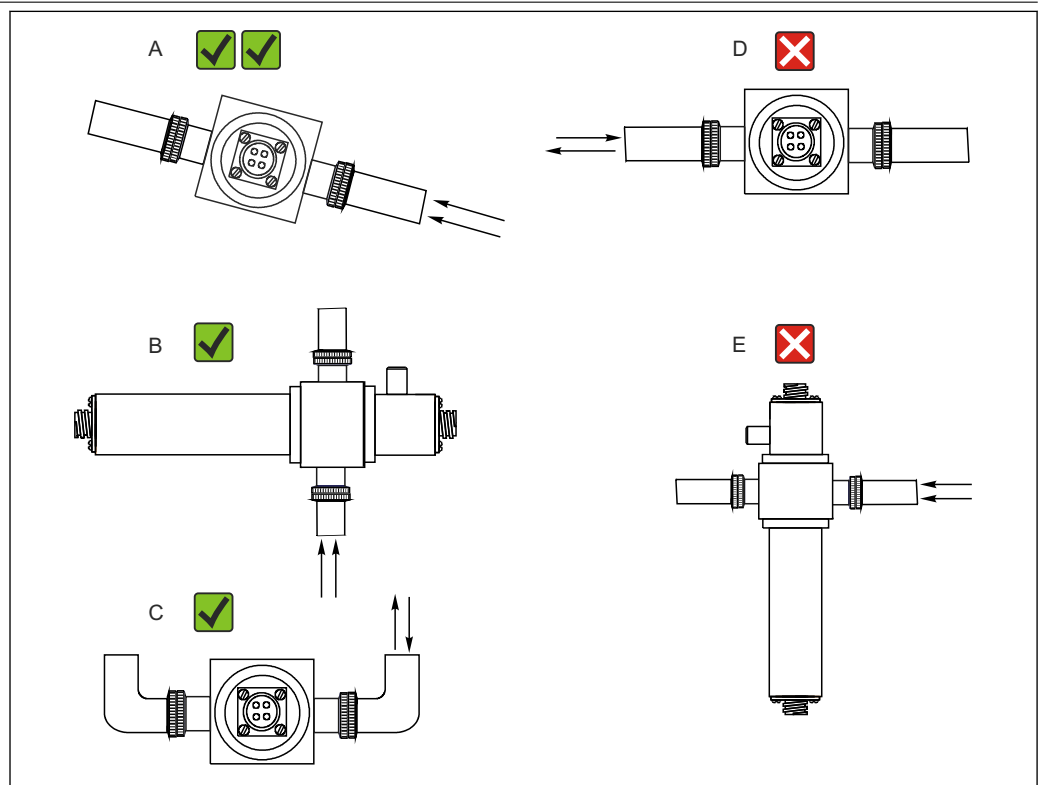

6 Mounting angles. The arrows indicate the direction of medium flow in the pipe.

- A Preferred mounting angle
- B Optimum mounting angle
- C Acceptable mounting angle
- D Mounting angle to be avoided
- E Forbidden mounting angle

Environment

Ambient temperature range	0 to 55 °C (32 to 130 °F)
Storage temperature	-10 to +70 °C (+10 to +160 °F)
Humidity	5 to 95 %
Degree of protection	IP 65 (NEMA 4) for all optical parts

Process

Process temperature	0 to 90 °C (32 to 194 °F) continuous Max. 130 °C (266 °F) for 2 hours
Process pressure	Max. 100 bar (1450 psi) absolute, depending on the material, pipe size and process connection of the flow assembly

Mechanical construction

Design, dimensions

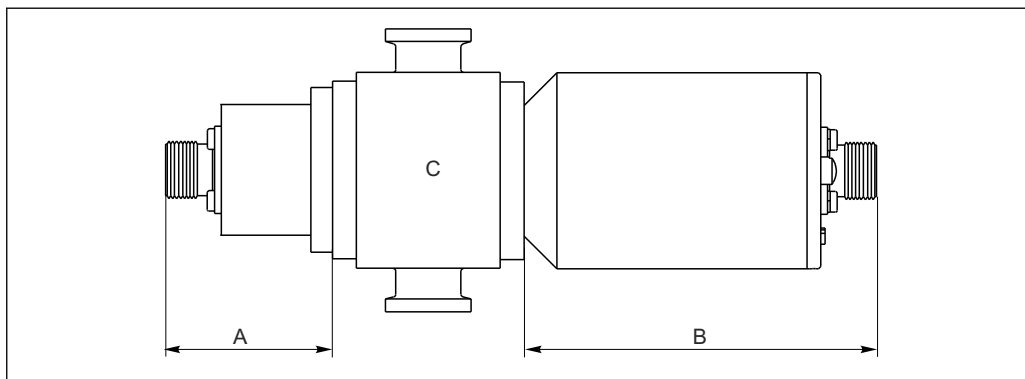

A0028304

 7 Sensor module

A Dimension of lamp, depends on lamp type, see table

B Dimension of detector, see table

C Assembly, see Technical Information for assembly

Lamp type	Dimension A in mm (inch)
High-luminescence lamp and standard incandescent lamp	33.78 (1.33)
Gas-filled lamp	33.78 (1.33)
Detector type	Dimension B in mm (inch)
Standard version with test filter	101.6 (4.0)

 The total length of the sensor module is derived from the lengths of the lamp, the detector and the assembly.

The dimensions of the OUA260 assembly are provided in Technical Information, TI00418C.

- ▶ When connecting the sensor cable, make sure you maintain an additional distance of 5 cm (2") on both the lamp side and the detector side of the sensor.

Weight	1.225 kg (2.7 lbs.), without flow assembly	
Materials	Sensor housing	Stainless steel 316L
	OUA260 assembly	Stainless steel 316, 316L or Kynar or customer-specific material
		Depends on version
	Cable connection ends	Nickel-plated brass
Light source	High-luminescence lamp (wavelength filter 450 nm and above)	
	Gas-filled high-performance lamp (wavelength filter below 450 nm)	
	Lamp operating life: typically 10 000 h	
Detector	UV silicon detectors, hermetically sealed	
Filter	Multilayer narrow-band interference filter	

Certificates and approvals

CE mark	<p>Declaration of Conformity</p> <p>The product meets the requirements of the harmonized European standards. As such, it complies with the legal specifications of the EC directives. The manufacturer confirms successful testing of the product by affixing to it the CE mark.</p>
Ex approvals	<ul style="list-style-type: none"> ▪ ATEX II 2G Ex db IIC T5 Gb ▪ FM Cl.1, Div. 1, Groups B, C, D
FDA conformity	<p>All non-metal parts in contact with medium, such as rubber and plastic parts, meet the requirements of FDA 21 CFR 177.2600. The plastic and elastomer parts of the sensor in contact with medium have passed the biological reactivity tests according to USP <87> and <88> Class VI.</p>

Ordering information

Product page	www.endress.com/ousaf22
Product Configurator	<p>On the product page there is a "Configuration" button to the right of the product image.</p> <ol style="list-style-type: none"> 1. Click this button. <ul style="list-style-type: none"> ↳ The Configurator opens in a separate window. 2. Select all the options to configure the device in line with your requirements. <ul style="list-style-type: none"> ↳ In this way, you receive a valid and complete order code for the device. 3. Export the order code as a PDF or Excel file. To do so, click the appropriate button on the right above the selection window. <p> For many products you also have the option of downloading CAD or 2D drawings of the selected product version. To do so, click the "CAD" tab and select the desired file type using drop-down lists.</p>
Scope of delivery	<p>The scope of delivery consists of the following depending on the version ordered:</p> <ul style="list-style-type: none"> ▪ sensor ▪ Detector and lamp module without flow assembly or ▪ Detector and lamp module mounted on OUA260 flow assembly ▪ Operating Instructions

If the sensor is ordered with a transmitter, the complete measuring system is factory-calibrated and shipped as one package.

If you have any questions, please contact your supplier or your local sales center.

Accessories



The following are the most important accessories available at the time this documentation was issued. For accessories not listed here, please contact your service or sales office.

Flow assembly

OUA260

- Flow assembly for hygienic sensors
- For sensor installation in pipes
- Materials: stainless steel 316, 316L or Kynar (other materials available on request)
- Wide variety of process connections and path lengths available
- Product Configurator on the product page: www.endress.com/oua260



Technical Information TI00418C

Cable

CUK80 cable set

- Pre-terminated and labeled cables for connecting analog photometer sensors
- Product Configurator on the product page: www.endress.com/cuk80

www.addresses.endress.com
