



## Plunger valve 3/2-way direct-acting

- Direct-acting, compact valve with diameter of up to DN 2.5
- Vibration-proof, bolted coil system
- Banjo threaded connection for direct mounting on pneumatic valves
- Explosion proof versions
- Energy-saving version with Kick and Drop available

Product variants described in the data sheet may differ from the product presentation and description.

### Can be combined with

- |   |  |   |
|---|--|---|
|   | <b>Type 2518</b><br>Cable plug,<br>form A according to<br>DIN EN 175301 -803 | ▶ |
|  | <b>Type 1087</b><br>Timer, form A according<br>to DIN EN 175301 -803         | ▶ |
|  | <b>Type 2509</b><br>Cable plug,<br>form A according to<br>DIN EN 175301 -803 | ▶ |

### Type description

Valve 6014 is a direct-acting plunger valve. The stopper and plunger guide tube are welded together to enhance pressure resistance and leak-tightness. Various seal material combinations are available depending on the application. A Bürkert-specific flange design (SFB) enables space-saving arrangement of valves on a manifold. Kick and Drop coils are available for the reduction of electrical power consumption during operation.

## Table of contents

<b>1. General technical data</b>	<b>3</b>
<b>2. Circuit functions</b>	<b>3</b>
<b>3. Approvals</b>	<b>4</b>
<b>4. Materials</b>	<b>4</b>
4.1. Chemical Resistance Chart – Bürkert resistApp.....	4
4.2. Material specifications .....	4
Standard version.....	4
Banjo version .....	5
Coil UL Listed (cULus) for hazardous locations, Class I, Division 2, cable version .....	5
Coil UL Listed (cULus) for hazardous locations, Class I, Division 2, terminal box version .....	6
<b>5. Dimensions</b>	<b>7</b>
5.1. Standard version.....	7
Pin assignment .....	8
5.2. Banjo version .....	9
5.3. Coil UL Listed (cULus) for hazardous locations, Class I, Division 2, cable version .....	10
5.4. Coil UL Listed (cULus) for hazardous locations, Class I, Division 2, terminal box version .....	11
5.5. Single manifold .....	12
5.6. Multiple manifold.....	12
Manifolds for block mounting .....	13
<b>6. Performance specifications</b>	<b>13</b>
6.1. Power consumption .....	13
6.2. Utilisation in another circuit function.....	13
6.3. Electrical data .....	14
<b>7. Product installation</b>	<b>14</b>
7.1. Installation notes.....	14
Control for impulse version with polarity reversal control.....	14
<b>8. Product accessories</b>	<b>15</b>
8.1. Cable glands for terminal box (UL Listed for hazardous locations, Class I, Division 2).....	15
8.2. Special tool to turn the terminal box .....	15
<b>9. Ordering information</b>	<b>16</b>
9.1. Bürkert eShop – Easy ordering and quick delivery .....	16
9.2. Bürkert product filter .....	16
9.3. Ordering chart .....	16
UL Recognized.....	16
UL Listed .....	18
UL Recognized banjo version .....	21
Coil UL Listed (cULus) for hazardous locations, Class I, Division 2 .....	21
9.4. Ordering chart accessories.....	23
Single manifold .....	23
Multiple manifold.....	23
Cable plug Type 2509, form A according to DIN EN 175301 - 803 .....	23
Cable plug Type 2518, form A according to DIN EN 175301 - 803 .....	23
Cable glands for ATEX/IECEX terminal box .....	24

## 1. General technical data

Product properties	
Dimensions	Detailed information can be found in chapter "5. Dimensions" on page 7.
Material	
Seal	FKM (EPDM on request)
Body	Brass or stainless steel 1.4305/303, polyamide (sub-base)
Coil	Polyamide (Epoxy on request)
Nominal diameter	DN 1.5...DN 2.5
Circuit function	C, D and T (see "2. Circuit functions" on page 3)
Thermal insulation class of solenoid coil	Polyamide class B Epoxy class H
Performance data	
Duty cycle / single valve assembly	100 % continuous rating Intermittent operation 60 % (30 min) or with 5 W coil (on request)
Electrical data	
Operating voltage	24 V DC, 24 V/50 Hz, 24 V/60 Hz, 110 V/50 Hz, 120 V/60 Hz, 230 V/50 Hz, 240 V/60 Hz (other voltages on request)
Voltage tolerance	± 10 %
Medium data	
Operating medium	Neutral gases and fluids (e.g. compressed air, town gas, natural gas, water, hydraulic oil, petrol). Suitable for technical vacuum.
Medium temperature	
With FKM	14 °F...+212 °F (PA coil), 14 °F...+248 °F (Epoxy coil), -40 °F on request
With PTFE/Graphite	-40 °F...+356 °F (see "4.1. Chemical Resistance Chart – Bürkert resistApp" on page 4)
With FKM, circuit function B	14 °F...212 °F (AC), 50 °F...248 °F (DC)
Viscosity	Max. 21 cSt
Process/Port connection & communication	
Port connection	G 1/8, G 1/4, NPT 1/8, NPT 1/4, sub-base (SFB)
Electrical connection	DIN EN 175 301 - 803 form A for cable plug <b>Type 2518</b> ▶ (see "9.4. Ordering chart accessories" on page 23) ATEX/IECEX version with 3 m moulded cable encapsulated
Approvals and certificates	
Degree of protection	IP65 with cable plug <b>Type 2518</b> ▶ NEMA 4X with cable plug <b>Type 2509</b> ▶ with stainless steel versions UL HazLoc Class I, Div 2 with terminal box or cable connection version
Environment and installation	
Installation position	Any, preferably actuator upright
Ambient temperature	Max. + 131 °F

## 2. Circuit functions

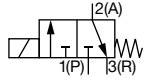
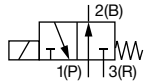
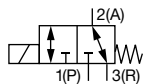
Symbol	Description
	<b>Circuit function C (CF C)</b> 3/2-way solenoid valve Direct-acting Normally closed
	<b>Circuit function D (CF D)</b> 3/2-way solenoid valve Direct-acting Normally open
	<b>Circuit function T (CF T)</b> 3/2-way solenoid valve Direct-acting Flow direction optional Normally closed

### 3. Approvals

Approvals	Description
	<b>ATEX and IECEx approval for coils with fixed cable outlet</b> ATEX: EPS 21 ATEX 1 234 X II 3G Ex ec IIC T4 Gc/II 3D Ex tc IIIC T130 °C Dc IECEx: IECEX EPS 21.0078X II 3G Ex ec IIC T4 Gc/II 3D Ex tc IIIC T130 °C Dc
	<b>ATEX and IECEx approval for coils with terminal box</b> ATEX: PTB 15 ATEX 1011 U IECEx: IECEX PTB 15.0037 U

### 4. Materials

#### 4.1. Chemical Resistance Chart – Bürkert resistApp

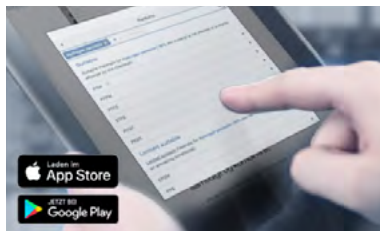

#### Bürkert resistApp – Chemical Resistance Chart

You want to ensure the reliability and durability of the materials in your individual application case? Verify your combination of media and materials on our website or in our resistApp.

[Start Chemical Resistance Check](#)

#### 4.2. Material specifications

##### Standard version

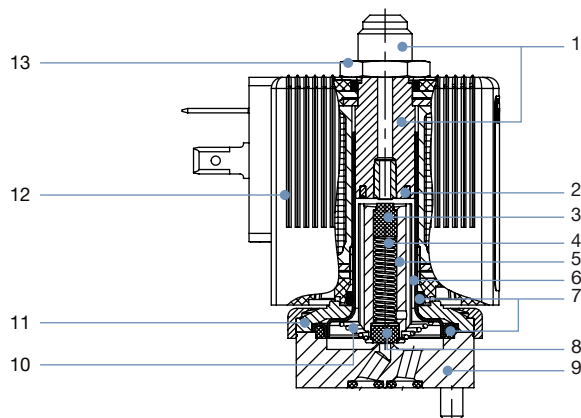

No.	Element	Material
1	Stopper	Stainless steel 1.4105/430F
2	Shading ring	Cu (brass version) Ag (stainless steel version)
3	Plunger seal	FKM
4	Spring	Stainless steel 1.4310/301
5	Magnetic core	Stainless steel 1.4105/430F
6	Armature guide tube	Stainless steel 1.4303/305/308
7	O-rings	FKM
8	Plunger seal	FKM
9	Valve body	Brass Stainless steel 1.4305/303 Stainless steel 1.4401/316
10	Spring	Stainless steel 1.4310/301
11	Sub-base	Steel, surface finish thick-film passivated (brass version) Stainless steel 1.4301/304 (stainless steel version)
12	Coil	PA (Polyamide) Epoxy (High temperature version)
13	Locknut	Steel, surface finish thick-film passivated (brass version) Stainless steel 1.4305/303 PTFE coated (stainless steel version)

Banjo version

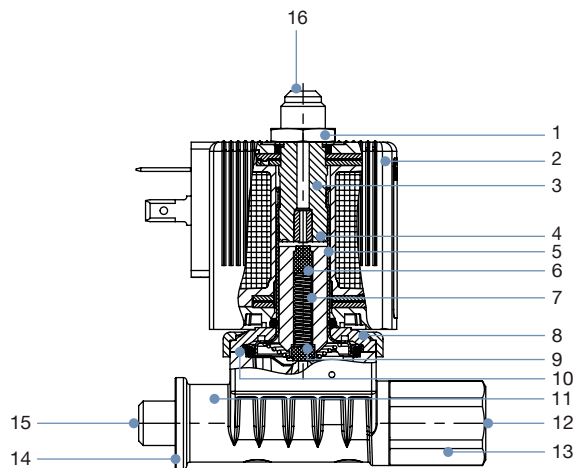

No.	Element	Material
1	Locknut	Steel, surface finish thick-film passivated (brass version) Stainless steel 1.4305/303 PTFE coated (stainless steel version)
2	Coil	PA (Polyamide) Epoxy (High temperature version)
3	Stopper	Stainless steel 1.4105/430F
4	Shading ring	Cu (brass version) Ag (stainless steel version)
5	Armature guide tube	Stainless steel 1.4303/305/308
6	Magnetic core	Stainless steel 1.4105/430F
7	Spring	Stainless steel 1.4310/301
8	Sub-base	Steel, surface finish thick-film passivated (brass version) Stainless steel 1.4301/304 (stainless steel version)
9	Plunger seal	FKM
10	O-rings	FKM
11	Valve body	PPS
12	Pressure connection P	-
13	Screw	Brass/Stainless steel 1.4301/304
14	O-rings	NBR
15	Pressure connection A	-
16	R connection	-

Coil UL Listed (cULus) for hazardous locations, Class I, Division 2, cable version

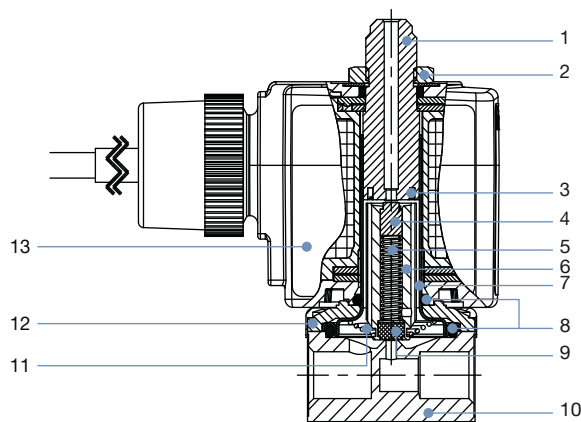

No.	Element	Material
1	Stopper	Stainless steel 1.4105/430F
2	Locknut	Steel, surface finish thick-film passivated (brass version) Stainless steel 1.4305/303 PTFE coated (stainless steel version)
3	Shading ring	Cu (brass version) Ag (stainless steel version)
4	Plunger seal	FKM
5	Spring	Stainless steel 1.4310/301
6	Magnetic core	Stainless steel 1.4105/430F
7	Armature guide tube	Stainless steel 1.4303/305/308
8	O-rings	FKM
9	Plunger seal	FKM
10	Valve body	Brass Stainless steel 1.4305/303 Stainless steel 1.4401/316
11	Spring	Stainless steel 1.4310/301
12	Sub-base	Steel, surface finish thick-film passivated (brass version) Stainless steel 1.4301/304 (stainless steel version)
13	Coil	Epoxy

DTS 1000582183 EN Version: - Status: RL (released | freigegeben | valide) printed: 24.05.2023

Coil UL Listed (cULus) for hazardous locations, Class I, Division 2, terminal box version

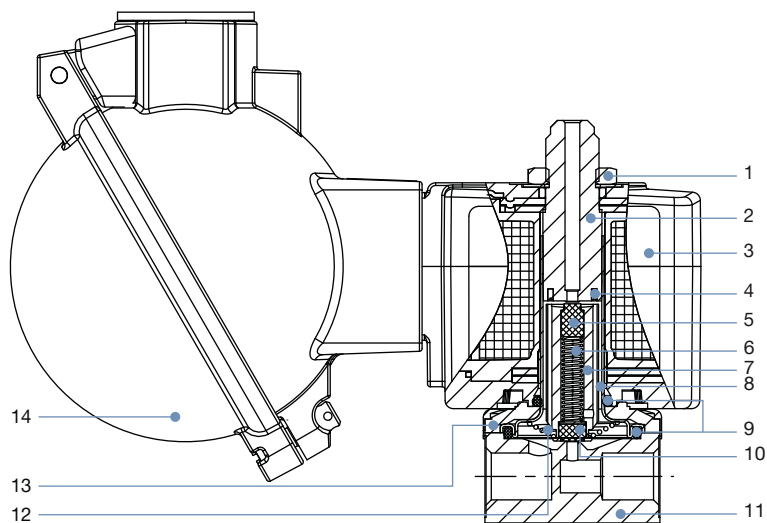

No.	Element	Material
1	Locknut	Steel, surface finish thick-film passivated (brass version) Stainless steel 1.4305/303 PTFE coated (stainless steel version)
2	Stopper	Stainless steel 1.4105/430F
3	Coil	Epoxy
4	Shading ring	Cu (brass version) Ag (stainless steel version)
5	Plunger seal	FKM
6	Spring	Stainless steel 1.4310/301
7	Magnetic core	Stainless steel 1.4105/430F
8	Armature guide tube	Stainless steel 1.4303/305/308
9	O-rings	FKM
10	Plunger seal	FKM
11	Valve body	Brass Stainless steel 1.4305/303 (G 1/8) Stainless steel 1.4401/316 (G 1/4)
12	Spring	Stainless steel 1.4310/301
13	Sub-base	Steel, surface finish thick-film passivated (brass version) Stainless steel 1.4301/304 (stainless steel version)
14	Terminal box	Aluminium

DTS 1000582183 EN Version: - Status: RL (released | freigegeben | valide) printed: 24.05.2023

## 5. Dimensions

### 5.1. Standard version

**Note:**

Dimensions in mm [inch]

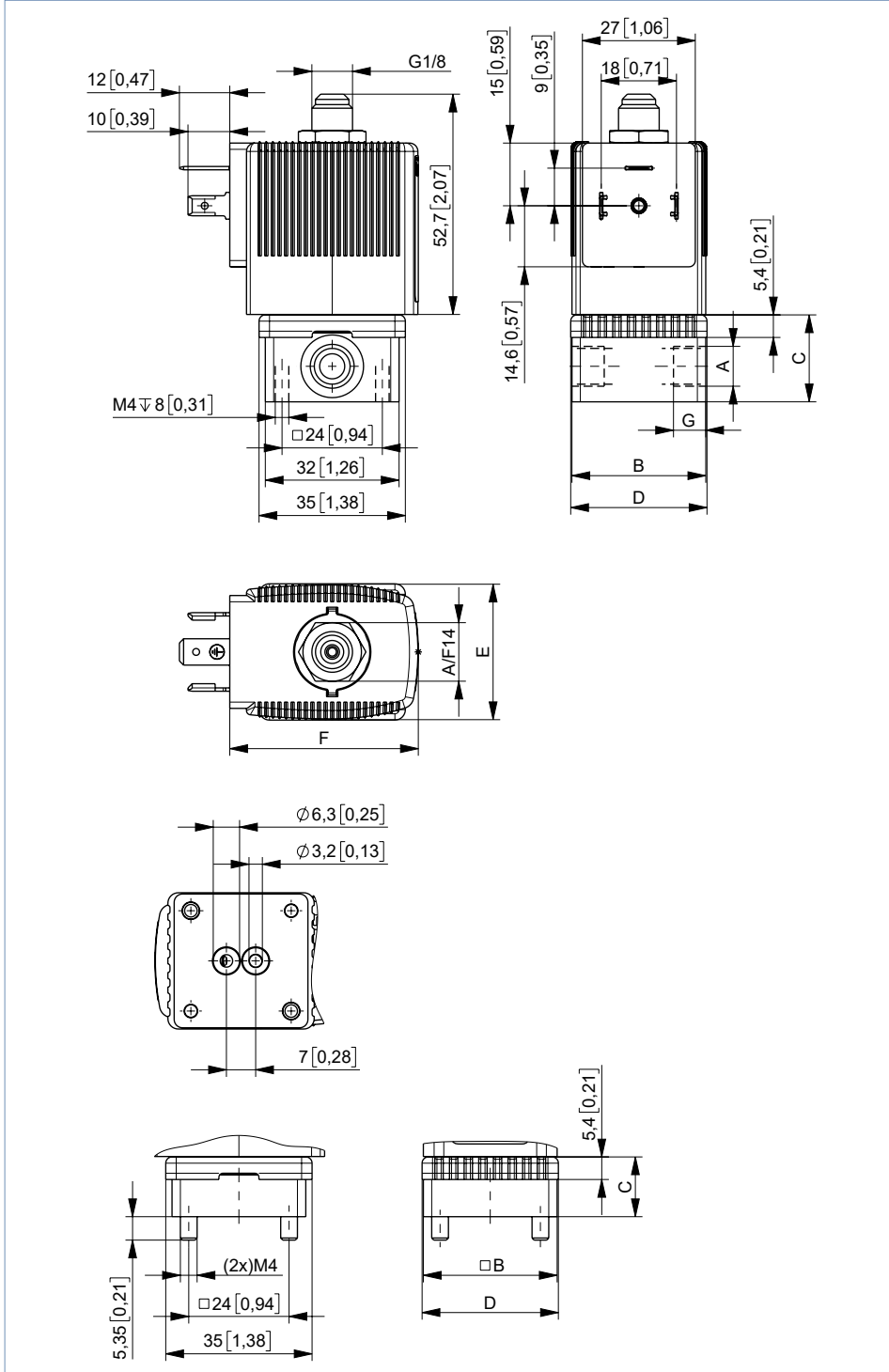

Port connection	A	B		C		D		G	
	[inch]	[mm]	[in]	[mm]	[in]	[mm]	[in]	[mm]	[in]
Threaded without manual override	G 1/8	32	1.26	20.8	0.82	32.6	1.28	8	0.31
	G 1/4	46	1.81	26.8	1.06	49	1.93	12	0.47
Threaded with manual override	G 1/8	32	1.26	20.8	0.82	32.6	1.28	8	0.31
	G 1/4	46	1.81	26.8	1.06	49	1.93	12	0.47
Sub-base	–	32	1.26	14.3	0.56	32.6	1.28	–	–

Coil size	E		F	
	[mm]	[in]	[mm]	[in]
5	32	1.26	45	1.77
6	40	1.57	51	2

### Pin assignment

For the positions marked with \*, \*\* or \*\*\* in the drawing, the connections are marked with the letters shown in the table above, depending on the circuit function. Unused circuit functions A or B connections will be closed off with a blanking plug or cap nut.

Circuit function	Connection Type		
	*	**	***
A	P	blank off	A
B	blank off	B	P
C	P	R	A
D	R	P	B
T	P	R	A



### 5.2. Banjo version

**Note:**

Dimensions in mm [inch]

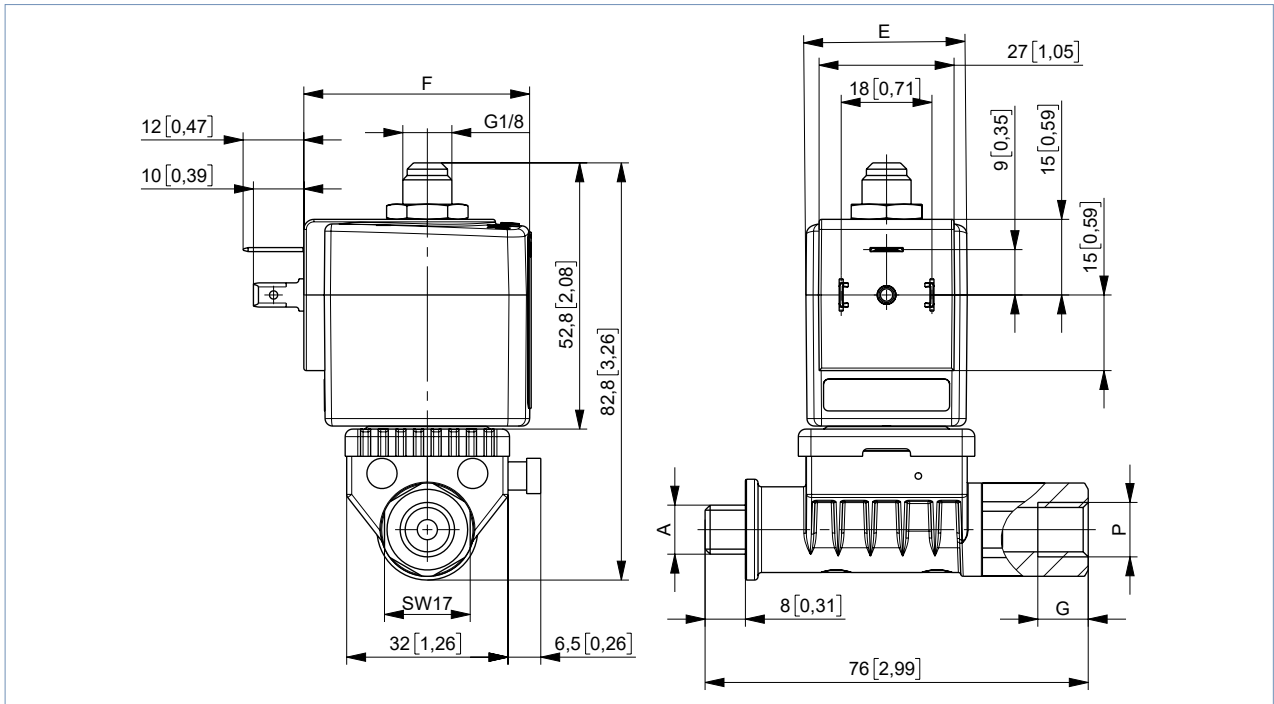

Port connection	A	P	G	
	[Zoll]	[Zoll]	[mm]	[in]
BJ01	G 1/8	G 1/8	10	0.39
BJ02	G 1/4	G 1/4		
BJ03	G 1/8	NPT 1/4		
BJ04	G 1/4	NPT 1/4		
BJ05	G 1/8	G 1/4		
BJ06	G 1/4	G 1/8		
BJ07	G 1/8	NPT 1/8		

Coil size	E		F	
	[mm]	[in]	[mm]	[in]
5	32	1.25	45	1.77
6	40	1.57	51	2

5.3. Coil UL Listed (cULus) for hazardous locations, Class I, Division 2, cable version

Note:

Dimensions in mm [inch]

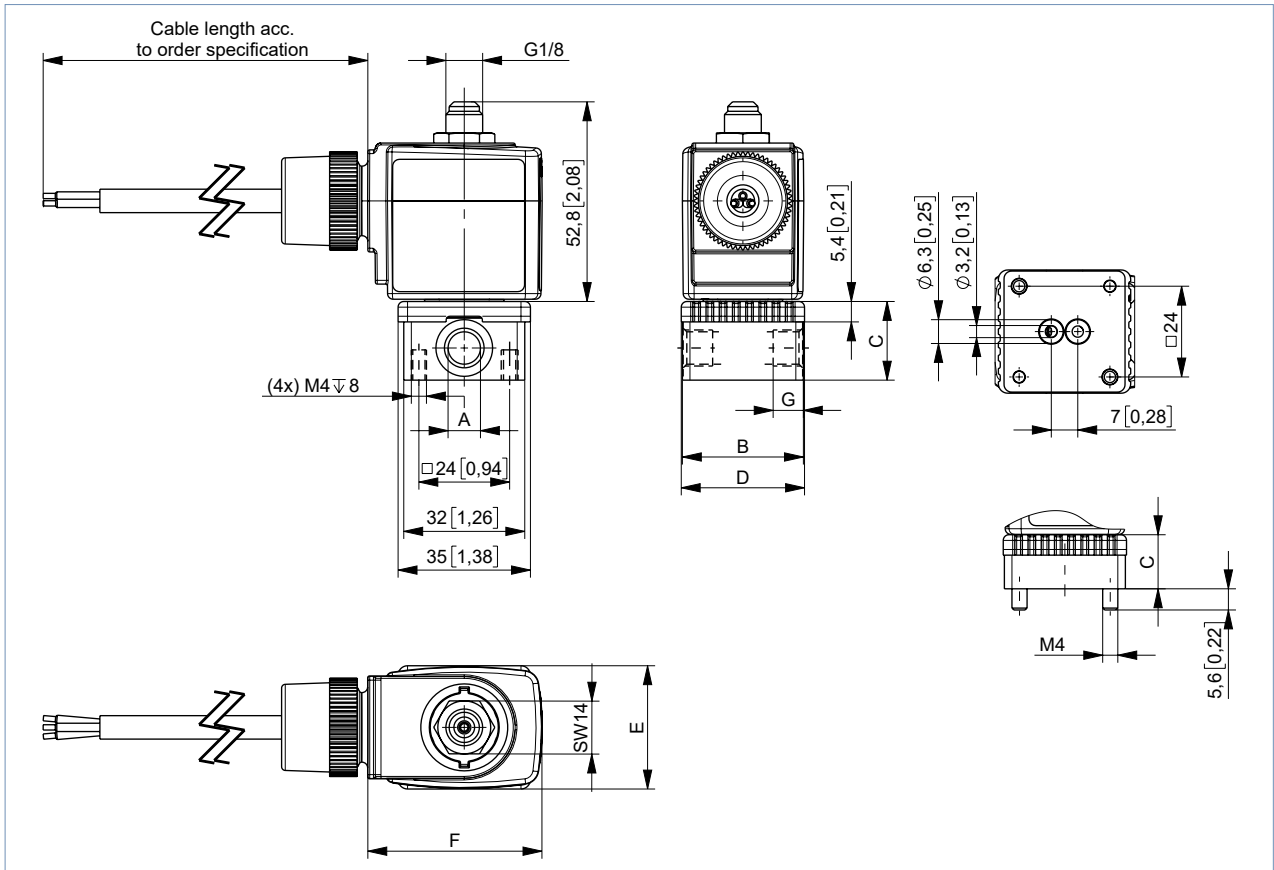

Port connection	A		B		C		D		G	
	[Zoll]	[mm]	[in]	[mm]	[in]	[mm]	[in]	[mm]	[in]	
Threaded version	G 1/8	32	1.26	20.8	0.82	32.6	1.28	8	0.31	
	G 1/4	46	1.81	26.8	1.06	49	1.93	12	0.47	
Sub-base version	-	32	1.25	14.3	0.56	32.6	1.28	-	-	

Coil size	E		F	
	[mm]	[in]	[mm]	[in]
5	32	1.26	46	1.81
6	40	1.57	52	2.04

5.4. Coil UL Listed (cULus) for hazardous locations, Class I, Division 2, terminal box version

**Note:**

Dimensions in mm [inch]

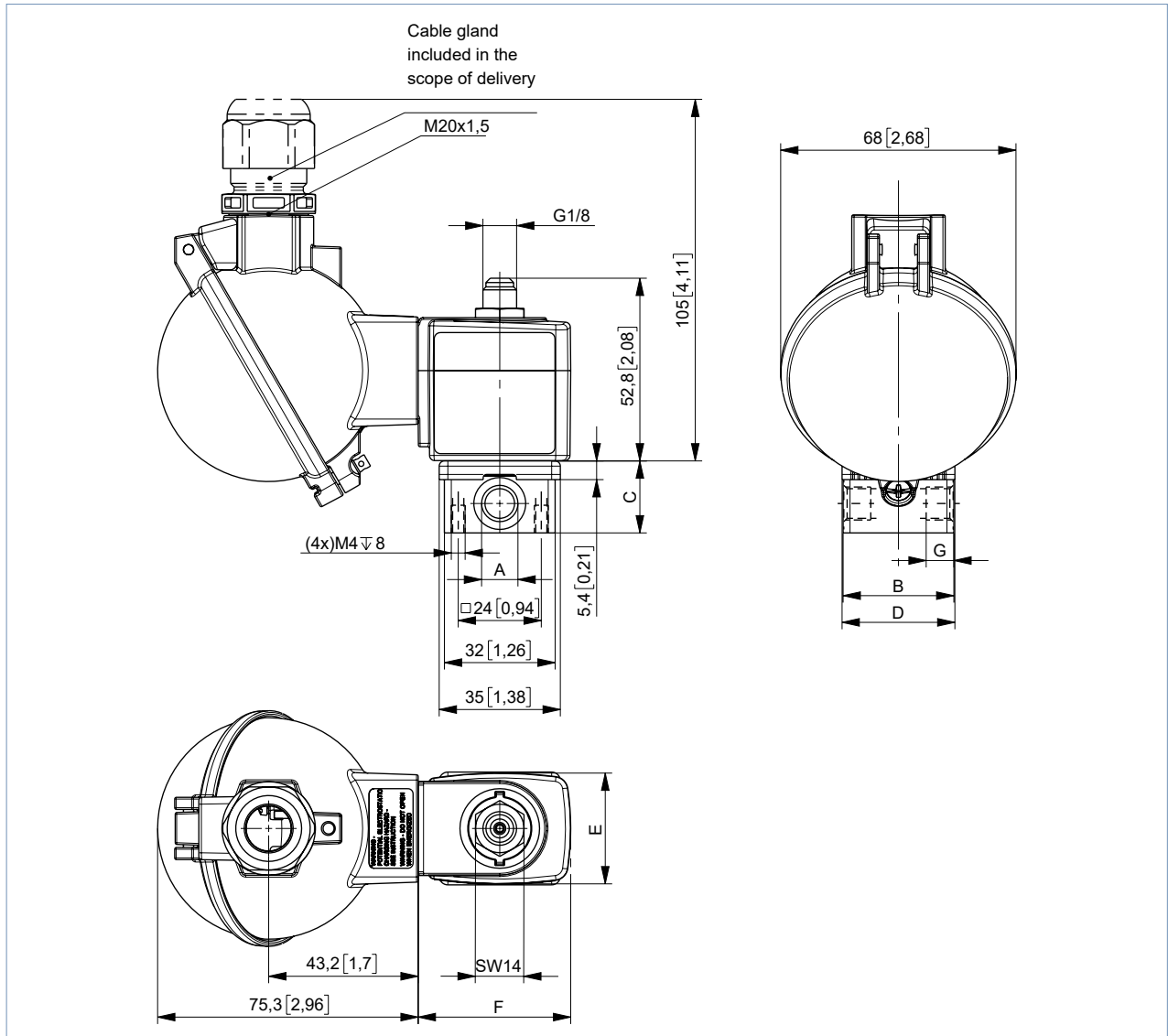

Port connection	A	B	C		D		G		
	[Zoll]	[mm]	[in]	[mm]	[in]	[mm]	[in]	[mm]	[in]
Threaded version	G 1/8	32	1.26	20.8	0.82	32.6	1.28	8	0.31
	G 1/4	46	1.81	26.8	1.06	49	1.93	12	0.47
Sub-base version	-	32	1.25	14.3	0.56	32.6	1.28	-	-

Coil size	E		F	
	[mm]	[in]	[mm]	[in]
5	32	1.26	44	1.73
6	40	1.57	51	2

### 5.5. Single manifold

**Note:**

- Dimensions in mm [inch]
- For detailed information on the installation of manifolds, see “Manifolds for block mounting” on page 13.

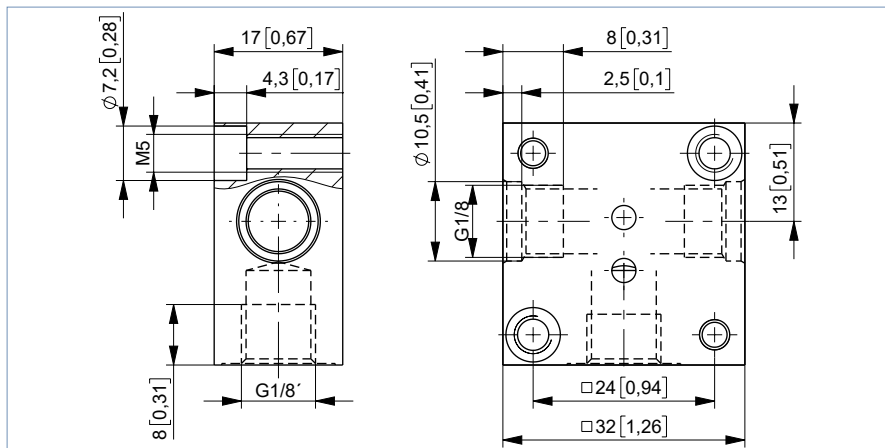

### 5.6. Multiple manifold

**Note:**

- Dimensions in mm [inch]
- Manifold only possible with coil size 5
- Brass or stainless steel manifolds on request

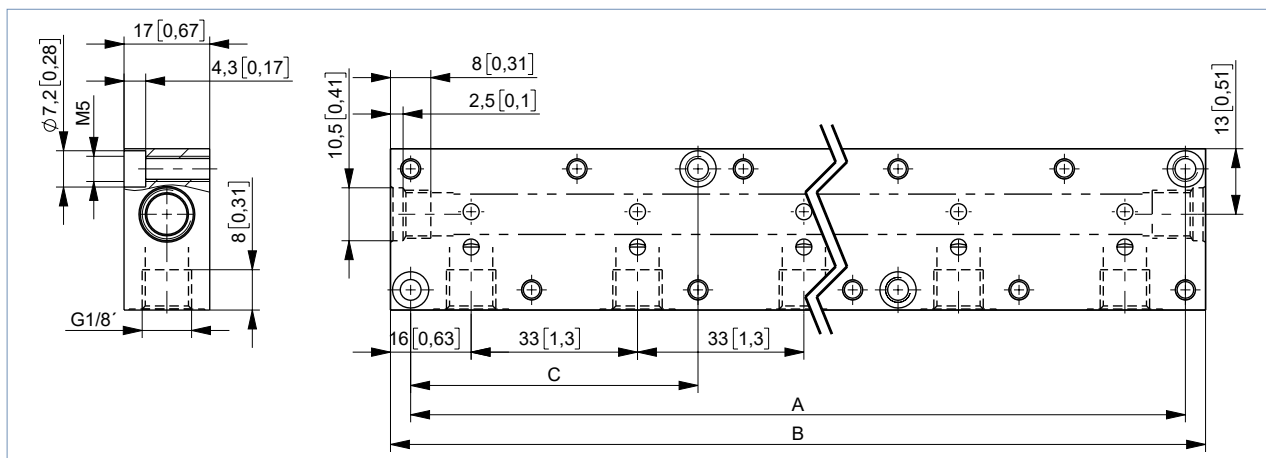

Accessory parts	Number of valve positions	Hole spacing A		Total length B		Hole spacing C		Article no.
		[mm]	[in]	[mm]	[in]	[mm]	[in]	
Multiple manifold (aluminium)	2	57	2.24	65	2.56	-	-	005023
	3	90	3.54	98	3.86	-	-	005286
	4	123	4.84	131	5.16	-	-	005287
	5	156	6.14	164	6.46	57	2.24	005035
	6	189	7.44	197	7.76	57	2.24	005038
	8	255	10	263	10.35	90	3.54	005386
	10	321	12.64	329	12.95	90	3.54	005764
Single manifold (aluminium)								005020
Plug nipple with O-rings for connecting manifolds								005040
Covering plate with screws and O-ring for closing off unused valve positions								005630

DTS 1000582183 EN Version: - Status: RL (released | freigegeben | valide) printed: 24.05.2023

### Manifolds for block mounting

#### Note:

- Unused, open valve ports must be closed off with covering plates (see accessories).
- Manifold should be fixed on to a rail.
- For detailed information on dimensions “5.6. Multiple manifold” on page 12.

With manifold mounting, please comply with the permissible duty cycle (5 W versions with 100 % continuous rating or 8 W version with 60 % duty cycle). The pressure port for the manifold is designated with P (R), and the outlet port with A (B). Only connect together ports with the same designation.

2/2-way valves of Type 6013 can be operated together on a manifold with 3/2-way valves of Type 6014, circuit function C (not D or T) if the operating pressures matches according to the rating plates. The manifolds can also be expanded if the valve functions are taken into consideration. Connector nipples with O-rings are used to connect the P (R) ports.

## 6. Performance specifications

### 6.1. Power consumption

Orifice [mm]	Power consumption				Response times <sup>1.)</sup>	
	Inrush AC [VA]	UC [W]	Hold AC [VA/W]	UC [W]	Opening [ms]	Closing [ms]
1.5	24	17	8	8/9	10...15	15...20
2.0					10...15	15...20
2.5					15...20	10...22

1.) Measurement at 87 psi and +68 °F at the valve outlet, opening: pressure build-up 0...90 %, closing: pressure reduction 100...10 %

### 6.2. Utilisation in another circuit function

The valves are equipped with different springs for specific circuit functions. When used with other circuit functions, the permissible operating pressure changes according to the following table.

Standard version		Max. operating pressure [bar] for valve application in circuit function				
DN	Circuit function	A	B	C	D	T
1.5	C	16	22	16	2	2
	D	2	2.5	2	16	2
	T	10	16	10	6	6
2.0	C	10	14	10	1	1
	D	1	1.5	1	10	1
	T	6	10	6	4	4
2.5	C	6	9	6	0.7	0.7
	D	0.7	1	0.7	6	0.7
	T	3.5	6	3.5	2.5	2.5

### 6.3. Electrical data

**Note:**

The valve is designed to operate on 24 V DC outputs through an intermediary intrinsically safe apparatus (isolating block or barrier). Detailed information can be found in the **operating instructions EPS 18 ATEX 1088X**.

Type of protection EEx ia IIC T6 acc. to PTB-No. Ex-96.D.2010

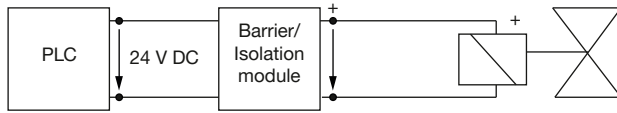

Function values for valve – circuit function	at +68 °F	at +131 °F
Minimum switching current	30 mA	30 mA
Nominal resistance coil	310 Ω	360 Ω
Minimum terminal voltage	9.3 V	10.8 V

Max. allowable values acc. to the certificate of conformity	
Ui	28 V
Ii	120 mA
Pi	1.1 W
Ambient temperature	+140 °F at T6 +167 °F at T5

## 7. Product installation

### 7.1. Installation notes

**Control for impulse version with polarity reversal control**

**Note:**

- Please use only the cable plug without electrical circuitry for the impulse version!
- Pulse duration at least 50 ms

Polarity (is marked on the coil with a label)	Features	Terminal connections
- switch ON +	valve open	(+) on terminal 2 and (-) on terminal 1 (see below)
+ switch OFF -	valve closed	(+) on terminal 1 and (-) on terminal 2 (see below)





DTS 1000582183 EN Version: - Status: RL (released | freigegeben | validé) printed: 24.05.2023

## 8. Product accessories

### 8.1. Cable glands for terminal box (UL Listed for hazardous locations, Class I, Division 2)

**Note:**

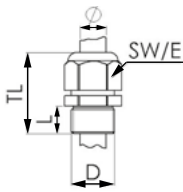
A cable gland in polyamide version is included in the delivery. A nickel-plated brass version can be ordered at a surcharge, see “9.4. Ordering chart accessories” on page 23.

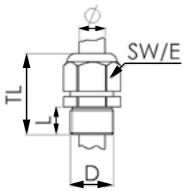
Description	Ex approvals		Dimensions										
	Certification	Identification											
Ex cable gland, Brass, nickel-plated, 6...13 mm 	PTB 04 ATEX 1112 X, IECEX PTB 13.0027X	II 2 G Ex e IIC Gb, II 2 D Ex tb IIIC Db IP68	 <table border="1"> <tr><td>TL</td><td>29...37 mm</td></tr> <tr><td>L</td><td>6 mm</td></tr> <tr><td>D</td><td>20 mm</td></tr> <tr><td>SW</td><td>24 mm</td></tr> <tr><td>E</td><td>27 mm</td></tr> </table>	TL	29...37 mm	L	6 mm	D	20 mm	SW	24 mm	E	27 mm
TL	29...37 mm												
L	6 mm												
D	20 mm												
SW	24 mm												
E	27 mm												
Ex cable gland, Polyamide, 7...13 mm 	PTB 13 ATEX 1015 X, IECEX PTB 13.0034X	II 2 G Ex e IIC Gb, II 2 D Ex tb IIIC Db IP68	 <table border="1"> <tr><td>TL</td><td>36...45 mm</td></tr> <tr><td>L</td><td>10 mm</td></tr> <tr><td>D</td><td>20 mm</td></tr> <tr><td>SW</td><td>24 mm</td></tr> <tr><td>E</td><td>28 mm</td></tr> </table>	TL	36...45 mm	L	10 mm	D	20 mm	SW	24 mm	E	28 mm
TL	36...45 mm												
L	10 mm												
D	20 mm												
SW	24 mm												
E	28 mm												

### 8.2. Special tool to turn the terminal box

**Note:**

This special tool is not supplied with the valve, see “9.4. Ordering chart accessories” on page 23.

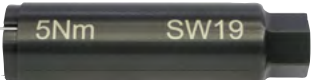
Description	Components of the set
Set SC02-AC10 	<ul style="list-style-type: none"> <li>• Special wrench</li> <li>• Service manual</li> </ul>

DTS 1000582183 EN Version: - Status: RL (released | freigegeben | validé) printed: 24.05.2023

## 9. Ordering information

### 9.1. Bürkert eShop – Easy ordering and quick delivery



**Bürkert eShop – Easy ordering and quick delivery**

You want to find your desired Bürkert product or spare part quickly and order directly? Our online shop is available for you 24/7. Sign up and enjoy all the benefits.

[Order online now](#)

### 9.2. Bürkert product filter



**Bürkert product filter – Get quickly to the right product**

You want to select products comfortably based on your technical requirements? Use the Bürkert product filter and find suitable articles for your application quickly and easily.

[Try out our product filter](#)

### 9.3. Ordering chart

#### UL Recognized

**Note:**

Please note that the cable plug **Type 2518** is included. UL Listed and other versions are available on request. For details see “Cable plug **Type 2509, form A** according to **DIN EN 175301 - 803**” on [page 23](#).

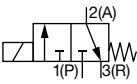
Circuit function	Port connection	Orifice	C <sub>v</sub> value water <sup>1.)</sup>	Voltage/ Frequency	Coil power	Pressure range <sup>2.)</sup> (MAWP <sup>3.)</sup>	Article no. Brass body	Article no. Stainless steel body
		[mm]	[gal/min]	[V/Hz]	[W]	[psi]		
<b>Threaded version with FKM seal, (class B)</b>								
<b>CF C</b> 3/2-way solenoid valve Direct-acting Normally closed 	NPT 1/8	1.5	0.08	024/DC	8	0...232	X	X
				024/60			X	X
				120/60			X	X
				240/60			X	X
	NPT 1/8	2.0	0.13	024/DC	8	0...145	X	X
				024/60			X	X
				120/60			X	X
				240/60			X	X
	NPT 1/4		0.13	024/DC	8	0...145	X	X
				024/60			X	X
				120/60			X	X
				240/60			X	X
	NPT 1/8	2.5	0.18	024/DC	8	0...87	X	X
				024/60			X	X
				120/60			X	X
				240/60			X	X
NPT 1/4		0.18	024/DC	8	0...87	X	X	
			024/60			X	X	
			120/60			X	X	
			240/60			X	X	

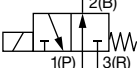
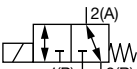
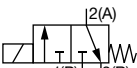
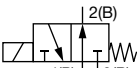

Circuit function	Port connection	Orifice	C <sub>v</sub> value water <sup>1.)</sup>	Voltage/ Frequency	Coil power	Pressure range <sup>2.)</sup> (MAWP <sup>3.)</sup> )	Article no. Brass body	Article no. Stainless steel body	
		[mm]	[gal/min]	[V/Hz]	[W]	[psi]			
<b>CF D</b> 3/2-way solenoid valve Direct-acting Normally open 	NPT 1/8	1.5	0.08	024/DC	8	0...232	X	X	
				024/60			X	X	
				120/60			X	X	
				240/60			X	X	
	NPT 1/8	2.0	0.13	024/DC	8	0...145	X	X	
				024/60			X	X	
				120/60			X	X	
				240/60			X	X	
	NPT 1/4		0.13	024/DC	8	0...145	X	X	
				024/60			X	X	
				120/60			X	X	
				240/60			X	X	
	NPT 1/8		2.5	0.18	024/DC	8	0...87	X	X
					024/60			X	X
					120/60			X	X
					240/60			X	X
NPT 1/4		0.18	024/DC	8	0...87	X	X		
			024/60			X	X		
			120/60			X	X		
			240/60			X	X		
<b>CF T</b> 3/2-way solenoid valve Direct-acting Flow direction optional Normally closed 	NPT 1/8	1.5	0.08	024/DC	8	0...102	X	X	
				024/60			X	X	
				120/60			X	X	
				240/60			X	X	
<b>With manual override</b>									
<b>CF C</b> 3/2-way solenoid valve Direct-acting Normally closed 	NPT 1/8	2.0	0.13	024/DC	8	0...145	X	X	
				024/60			X	X	
				120/60			X	X	
				240/60			X	X	
	NPT 1/4		0.13	024/DC	8	0...145	X	X	
				024/60			X	X	
				120/60			X	X	
				240/60			X	X	
<b>CF D</b> 3/2-way solenoid valve Direct-acting Normally open 	NPT 1/8	2.0	0.13	024/DC	8	0...145	X	X	
				024/60			X	X	
				120/60			X	X	
				240/60			X	X	
	NPT 1/4		0.13	024/DC	8	0...145	X	X	
				024/60			X	X	
				120/60			X	X	
				240/60			X	X	

X: on request

1.) Measurement at 14 psi<sup>2)</sup> and +68 °F at the valve inlet and free outlet

2.) Pressure data: Overpressure to atmospheric pressure

3.) Maximum allowable working pressure

## UL Listed

## Note:

Please note that the cable plug **Type 2509** ▶ is included. UL Listed and other versions are available on request. For details see "Cable plug **Type 2509, form A** according to **DIN EN 175301 - 803**" on page 23.

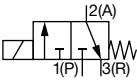
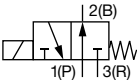
Circuit function	Port connection	Orifice	C <sub>v</sub> value water <sup>1)</sup>	Voltage/ Frequency	Coil power	Pressure range <sup>2)</sup> (MAWP <sup>3)</sup> )	Article no. Brass body	Article no. Stainless steel body
		[mm]	[gal/min]	[V/Hz]	[W]	[psi]		
<b>Threaded version with FKM seal, (class B)</b>								
<b>CF C</b> 3/2-way solenoid valve Direct-acting Normally closed 	NPT 1/8	1.5	0.08	024/DC	8	0...232	X	X
				024/60			X	X
				120/60			X	X
				240/60			X	X
	NPT 1/8	2.0	0.13	024/DC	8	0...145	X	X
				024/60			X	X
				120/60			X	X
				240/60			X	X
	NPT 1/4		0.13	024/DC	8	0...145	X	X
				024/60			X	X
				120/60			X	X
				240/60			X	X
	NPT 1/8	2.5	0.18	024/DC	8	0...87	X	X
				024/60			X	X
				120/60			X	X
				240/60			X	X
	NPT 1/4		0.18	024/DC	8	0...87	X	X
				024/60			X	X
				120/60			X	X
				240/60			X	X
<b>CF D</b> 3/2-way solenoid valve Direct-acting Normally open 	NPT 1/8	1.5	0.08	024/DC	8	0...232	X	X
				024/60			X	X
				120/60			X	X
				240/60			X	X
	NPT 1/8	2.0	0.13	024/DC	8	0...145	X	X
				024/60			X	X
				120/60			X	X
				240/60			X	X
	NPT 1/4		0.13	024/DC	8	0...145	X	X
				024/60			X	X
				120/60			X	X
				240/60			X	X
	NPT 1/8	2.5	0.18	024/DC	8	0...87	X	X
				024/60			X	X
				120/60			X	X
				240/60			X	X
	NPT 1/4		0.18	024/DC	8	0...87	X	X
				024/60			X	X
				120/60			X	X
				240/60			X	X

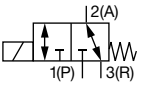
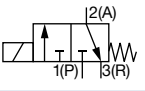
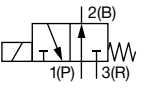
Circuit function	Port connection	Orifice	C <sub>v</sub> value water <sup>1.)</sup>	Voltage/Frequency	Coil power	Pressure range <sup>2.)</sup> (MAWP <sup>3.)</sup>	Article no. Brass body	Article no. Stainless steel body
		[mm]	[gal/min]	[V/Hz]	[W]	[psi]		
<b>CF T</b> 3/2-way solenoid valve Direct-acting Flow direction optional Normally closed 	NPT 1/8	1.5	0.08	024/DC	8	0...102	X	X
				024/60			X	X
				120/60			X	X
				240/60			X	X
<b>With manual override</b>								
<b>CF C</b> 3/2-way solenoid valve Direct-acting Normally closed 	NPT 1/8	2.0	0.13	024/DC	8	0...145	X	X
				024/60			X	X
				120/60			X	X
				240/60			X	X
	NPT 1/4	0.13	024/DC	8	0...145	X	X	
			024/60			X	X	
			120/60			X	X	
			240/60			X	X	
<b>CF D</b> 3/2-way solenoid valve Direct-acting Normally open 	NPT 1/8	2.0	0.13	024/DC	8	0...145	X	X
				024/60			X	X
				120/60			X	X
				240/60			X	X
	NPT 1/4	0.13	024/DC	8	0...145	X	X	
			024/60			X	X	
			120/60			X	X	
			240/60			X	X	

X: on request

1.) Measurement at 14 psi<sup>2)</sup> and +68 °F at the valve inlet and free outlet

2.) Pressure data: Overpressure to atmospheric pressure

3.) Maximum allowable working pressure

**Note:**

Please note that the cable plug **Type 2509** ▶ is included. UL Listed and other versions are available on request. For details see “**Cable plug Type 2509, form A according to DIN EN 175301 - 803**” on page 23.

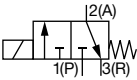
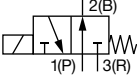
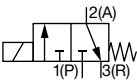
Circuit function	Orifice	C <sub>v</sub> value water <sup>1.)</sup>	Voltage/ Frequency	Coil power	Pressure range <sup>2.)</sup> (MAWP <sup>3.)</sup> )	Article no. Brass body	Article no. Stainless steel body		
	[mm]	[gal/min]	[V/Hz]	[W]	[psi]				
<b>Threaded version with FKM seal, (class B)</b>									
<b>CF C</b> 3/2-way solenoid valve Direct-acting Normally closed 	1.5	0.08	024/DC	8	0...232	X	X		
			024/60			X	X		
			120/60			X	X		
			240/60			X	X		
	2.0	0.13	024/DC	8	0...145	X	X		
			024/60			X	X		
			120/60			X	X		
			240/60			X	X		
<b>CF D</b> 3/2-way solenoid valve Direct-acting Normally open 	2.0	0.13	024/DC	8	0...145	X	X		
			024/60			X	X		
			120/60			X	X		
			240/60			X	X		
<b>With manual override</b>									
<b>CF C</b> 3/2-way solenoid valve Direct-acting Normally closed 	1.5	0.08	024/DC	5	0...145	X	X		
			024/60			X	X		
			120/60			X	X		
			240/60			X	X		
	0.08	0.08	0.08	024/DC	8	0...232	X	X	
				024/60			X	X	
				120/60			X	X	
				240/60			X	X	
	2.0	0.13	0.13	024/DC	5	0...87	X	X	
				024/60			X	X	
				120/60			X	X	
				240/60			X	X	
		0.13	0.13	0.13	024/DC	8	0...145	X	X
					024/60			X	X
					120/60			X	X
					240/60			X	X

X: on request

1.) Measurement at 14 psi<sup>2.)</sup> and +68 °F at the valve inlet and free outlet

2.) Pressure data: Overpressure to atmospheric pressure

3.) Maximum allowable working pressure

DTS 1000582183 EN Version: - Status: RL (released | freigegeben | valide) printed: 24.05.2023

## UL Recognized banjo version

## Note:

Please note that the cable plug **Type 2518** ▶ is included. UL Listed and other versions are available on request. For details see "Cable plug **Type 2509, form A** according to **DIN EN 175301 - 803**" on page 23.

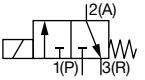
Circuit function	Port connection	Orifice	Q <sub>Nn</sub> value air	Voltage/Frequency	Power consumption	Pressure range (MAWP <sup>1.)</sup> )	Article no. Brass body	Article no. Stainless steel body	
		[mm]	[gal/min]	[V/Hz]	[W]	[psi]			
<b>Threaded version with FKM seal, (class B)</b>									
<b>CF C</b> 3/2-way solenoid valve Direct-acting Normally closed 	NPT 1/8	1.5	2.65	024/DC	8	0...232	X	X	
				120/60			X	X	
	NPT 1/4			2.65	024/DC	8	0...232	X	X
					120/60			X	X
	NPT 1/8	2.0		4.24	024/DC	8	0...232	X	X
					120/60			X	X
	NPT 1/4			4.24	024/DC	8	0...232	X	X
					120/60			X	X

X: on request

1.) Maximum allowable working pressure

## Coil UL Listed (cULus) for hazardous locations, Class I, Division 2

## Note:

- The maximum medium temperature may never exceed the permissible temperature class (T4 275 °F, T5 212 °F, T6 185 °F) minus 5K.
- With 3 m/9'10" cable as standard. Other lengths or version with junction box on request.

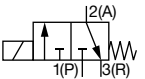
Circuit function	Port connection	Orifice	C <sub>v</sub> value water	Voltage/frequency	Coil power	Pressure range (MAWP <sup>1.)</sup> )	Article no. PA body	Article no. Brass body	
		[mm]	[gal/min]	[V/Hz]	[W]	[psi]			
<b>Approved for block mounting, ambient temperature from +14 °F...+104 °F, with FKM seal and manual override</b>									
<b>CF C</b> 3/2-way solenoid valve Direct-acting Normally closed 	Sub-base (SFB)	1.5	0.08	024/UC	7	0...145	X	X	
				120/UC			X	X	
				024/UC	7		X	X	
				120/UC			X	X	
	Sub-base (SFB)	2.0		0.13	024/UC	7	0...87	X	X
					120/UC			X	X

X: on request

1.) Maximum allowable working pressure

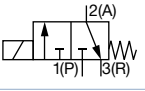
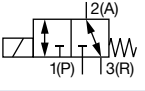
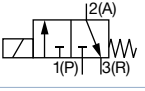
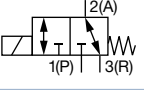
Circuit function	Port connection	Orifice	C <sub>v</sub> value water	Voltage/frequency	Coil power	Pressure range (MAWP <sup>1.)</sup> )	Article no. PA body	Article no. Brass body
		[mm]	[gal/min]	[V/Hz]	[W]	[psi]		
<b>Approved for single mounting, ambient temperature from +14 °F...+131 °F, with FKM seal, without manual override</b>								
<b>CF C</b> 3/2-way solenoid valve Direct-acting Normally closed 	NPT 1/8	2.0	0.13	024/UC	9	0...145	X	X
				120/UC			X	X
	NPT 1/4	2.5	0.13	024/UC	9	0...145	X	X
				120/UC			X	X
	NPT 1/8	2.5	0.18	024/UC	9	0...87	X	X
				120/UC			X	X
	NPT 1/4	2.5	0.18	024/UC	9	0...87	X	X
				120/UC			X	X
<b>CF T</b> 3/2-way solenoid valve Direct-acting Flow direction optional Normally closed 	NPT 1/8	1.5	0.08	024/UC	9	0...7	X	X
				120/UC			X	X
	NPT 1/4	1.5	0.08	024/UC	9	0...102	X	X
				120/UC			X	X
<b>With manual override</b>								
<b>CF C</b> 3/2-way solenoid valve Direct-acting Normally closed 	NPT 1/8	2.0	0.13	024/UC	9	0...145	X	X
				120/UC			X	X
	NPT 1/4	2.5	0.13	024/UC	9	0...145	X	X
				120/UC			X	X
	NPT 1/8	2.5	0.18	024/UC	9	0...87	X	X
				120/UC			X	X
	NPT 1/4	2.5	0.18	024/UC	9	0...87	X	X
				120/UC			X	X
<b>CF T</b> 3/2-way solenoid valve Direct-acting Flow direction optional Normally closed 	NPT 1/8	1.5	0.08	024/UC	9	0...7	X	X
				120/UC			X	X
	NPT 1/4	1.5	0.08	024/UC	9	0...102	X	X
				120/UC			X	X

X: on request

1.) Maximum allowable working pressure

Further versions on request	
<b>Additional</b> Orifice: 1.2 mm, 3.0 mm	<b>Process connection</b> Banjo bolt
<b>Approval</b> UL, CSA	<b>Voltage</b> Non-standard voltages
<b>Material</b> Epoxy coil according to form A Seal material EPDM	

DTS 1000582183 EN Version: - Status: RL (released | freigegeben | valide) printed: 24.05.2023

### 9.4. Ordering chart accessories

#### Singel manifold

**Note:**

Detailed ordering information can be found in chapter **“5.5. Single manifold”** on page 12.

#### Multiple manifold

**Note:**

Detailed ordering information can be found in chapter **“5.6. Multiple manifold”** on page 12.

#### Cable plug Type 2509, form A according to DIN EN 175301 - 803

**Note:**

- The cable plug meets the requirements for UL hazloc Div. 2
- Without circuitry (Standard)
- For more information on the cable plug, see data sheet **Type 2509** ▶.

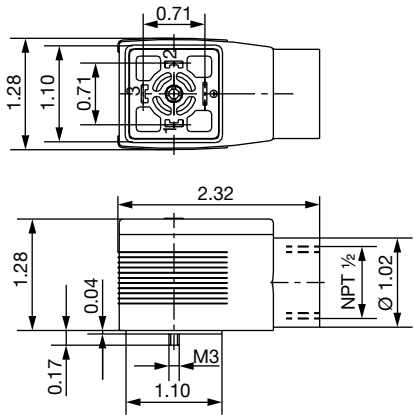
Cable plug	Dimensions	Version	Voltage	Article no.
		Without circuitry	0...250 V AC/DC	137943

#### Cable plug Type 2518, form A according to DIN EN 175301 - 803

**Note:**

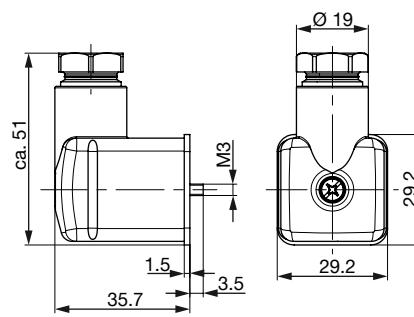

For further versions see data sheet **Type 2518** ▶.

Cable plug	Dimensions	Version	Voltage	Article no.
		Without circuitry (AC/DC)	0...250 V AC/DC	314802
		With LED (AC/DC)	12...24 V AC/DC	314812
		With LED and varistor (AC/DC)	12...24 V AC/DC	314820
		With rectifier, LED and varistor	12...24 V AC/DC	314816

DTS 1000582183 EN Version: - Status: RL (released | freigegeben | valide) printed: 24.05.2023

**Cable glands for ATEX/IECEX terminal box****Note:**

- A cable gland in polyamide version is included in the delivery. A nickel-plated brass version can be ordered at surcharge.
- For more information on Ex cable glands, see “8.1. Cable glands for terminal box (UL Listed for hazardous locations, Class I, Division 2)” on page 15.

Description	Article no.
Ex cable gland, brass, nickel-plated, 6...13 mm <sup>1.)</sup>	773278 
Ex cable gland, polyamide, 7...13 mm <sup>1.)</sup>	773277 
Set SC02-AC10: Special wrench <sup>2.)</sup> incl. service manual	293488 

1.) Cable diameter

2.) Not included in the scope of delivery of the valve



# Bürkert – Close to You

For up-to-date addresses  
please visit us at  
[www.burkert.com](http://www.burkert.com)

DTS 1000582183 EN Version: - Status: RL (released | freigegeben | valide) printed: 24.05.2023

Austria  
Belgium  
Czech Republic  
Denmark  
Finland  
France  
Germany  
Italy  
Netherlands

Norway  
Poland  
Spain  
Sweden  
Switzerland  
Turkey  
United Kingdom



Canada  
USA

Brazil  
Uruguay

South Africa

United  
Arab  
Emirates

Australia  
New Zealand

China  
Hong Kong  
India  
Japan  
Korea  
Malaysia  
Philippines  
Singapore  
Taiwan