









EDIP Process display

- Display with büS Interface (CANopen) in 3.5" (8.9 cm) und 7" (17.8 cm) size
- Displays up to 4 or 64 process values, parameter and associated status information
- Touch Display supporting time plots, editing of proces parameter and execution of pre-configured actions (7" Display)
- Easy integration and combination with other devices in the Bürkert EDIP platform
- Flexible mounting options for DIN rail clip, pipe mounting and wall mounting with a magnetic holder

Product variants described in the data sheet may differ from the product presentation and description.

Can be combined with

	Type ME43 Fieldbus gateway	▶
	Type ME63 Industrial Ethernet gateway, IP65/ IP67/ IP69k	▶
	Type 8741 Mass Flow Controller (MFC)/ Mass Flow Meter (MFM) for Gases	▶
	Type 8802 ELEMENT continuous control valve systems - overview	▶
	Type 8681 Control head for decentralized automation of hygienic process valves	▶
	Type 8652 AirLINE - the valve island optimised for process automation	▶
	Type 8905 Online Analysis System	▶

Type description

The process view display Type ME61 extends the EDIP (Efficient Device Integration Platform) with an easily attachable display for process parameters. The device provides a Bürkert system bus interface (büS) using an M12 connector, which allows easy integration with existing büS or CANopen environments. Using the EDIP configuration tool (Bürkert Communicator) the ME61 can be easily set up to display the desired information.

Table of contents

1. General technical data	3
2. Dimensions	4
2.1. Display Type ME61 (3.5").....	4
2.2. Display Type ME61 (7").....	4
3. Device/Process connections	5
3.1. Pin assignment	5
4. Product design and assembly	5
4.1. Product features	5
Display Type ME61 (3.5").....	5
Display Type ME61 (7").....	5
5. Product accessories	6
5.1. EDIP – Efficient Device Integration Platform.....	6
5.2. Software Bürkert Communicator	6
6. Networking and combination with other Bürkert products	7
7. Ordering information	7
7.1. Bürkert eShop – Easy ordering and quick delivery.....	7
7.2. Bürkert product filter.....	8
7.3. Ordering chart.....	8
7.4. Ordering chart accessories.....	8

1. General technical data

Product properties	
Dimensions	Detailed information can be found in chapter "2. Dimensions" on page 4.
Weight	0.2 kg (3.5") – 0.35 kg (7")
Material	
Body	PC (Polycarbonate)
Status indication	Integrated in the display for status indication of the connected devices (according to configuration)
Electrical data	
Operating voltage	24 V DC \pm 10 % (max. residual ripple 10 %)
Power consumption of the module	3 W
Process/Port connection & communication	
Communication interface	Bürkert system bus (bÜS) for integration of the display into a CANopen/bÜS network via X1 (M12 connector)
Electrical connection	M12, A-coded, 5 pin plug (integrated with communication interface X1)
Approvals and certificates	
Approvals	
CE	EU-Conformity
Environment and installation	
Ambient temperature	-20 °C...+60 °C
Storage temperature	-30 °C...+80 °C
Degree of protection	IP65/66/67

2. Dimensions

2.1. Display Type ME61 (3.5")

Note:

Dimensions in mm

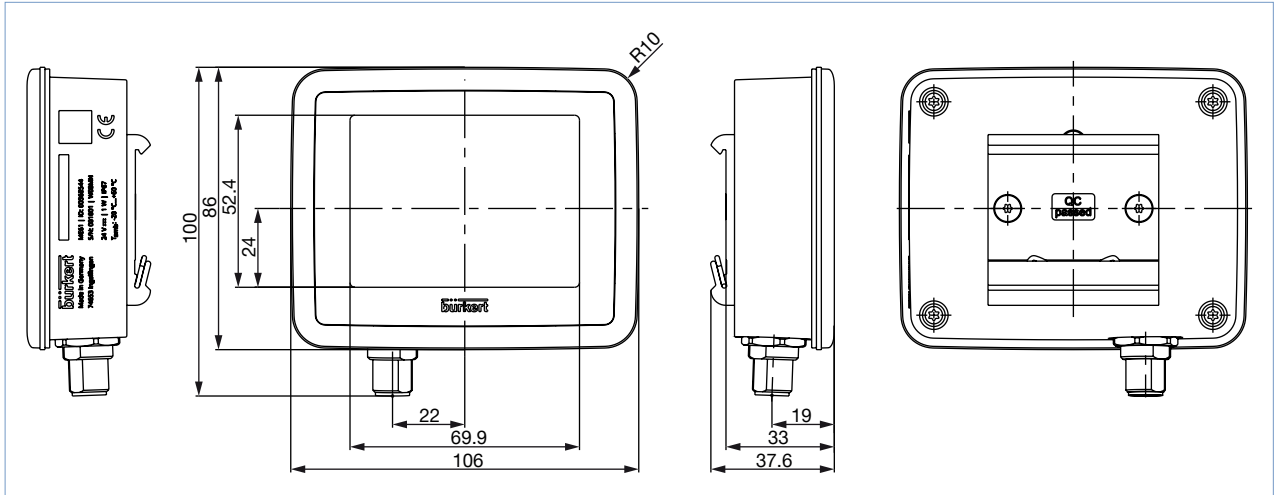

2.2. Display Type ME61 (7")

Note:

Dimensions in mm

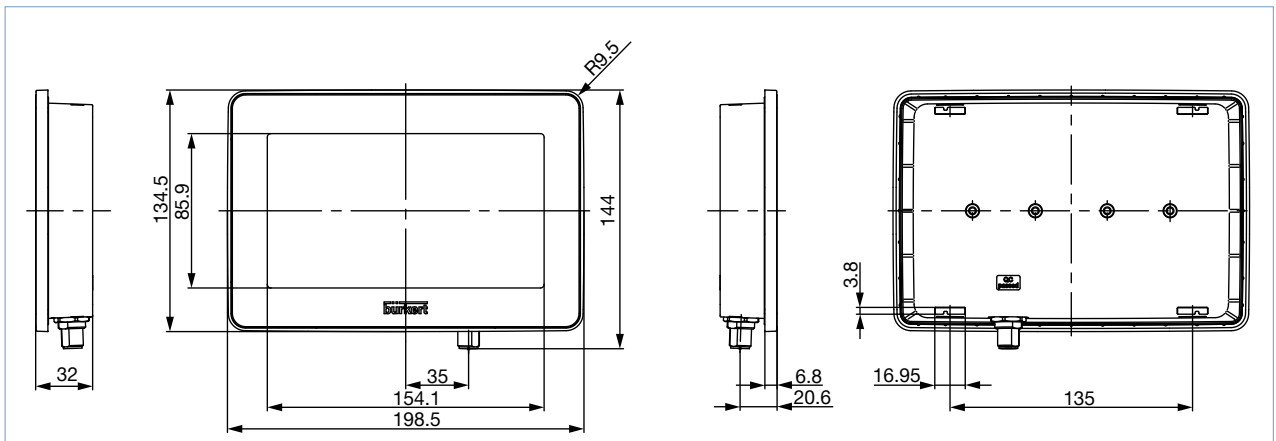

3. Device/Process connections

3.1. Pin assignment



M12, X1 (plug), A-coded, 5-pol	Pin	Assignment	Function
	1	FE/CAN_GND	Shield
	2	24 V	Power supply
	3	GND	Power supply
	4	CAN_H	büS/CANopen communication
	5	CAN_L	büS/CANopen communication

4. Product design and assembly

4.1. Product features

Display Type ME61 (3.5")



Function:

Visualization of up to four process values in a büS/CANopen network

Communication/Power supply:

büS/CANopen, M12, A-coded, 5 pin

Display Type ME61 (7")



Function:

Visualization of up to 64 process values in a büS/CANopen network

Graphical display of time curves of process values

Programmable touch function for triggering functions

Communication/Power supply:

büS/CANopen, M12, A-coded, 5 pin

5. Product accessories

5.1. EDIP – Efficient Device Integration Platform

EDIP is the new Bürkert device platform that will standardize the operation, communication and interfaces of many process devices (e.g. sensors, mass flow controllers) in the future. Thanks to EDIP, devices can be intelligently networked and operated with the standardized software, the Bürkert Communicator. The basis and link of EDIP is a digital interface based on the CANopen standard. EDIP offers the user the following advantages:

- Interoperability - guaranteed by the uniform interface
- Comfortable operation and display concept
- Faster and simplified commissioning
- Modularity - allows the devices to be adapted to individual customer requirements
- Easy transfer and fusion of device settings

5.2. Software Bürkert Communicator

Note:

To install the software, click [here](#) ►.

Part of Bürkert's new EDIP program (Efficient Device Integration Platform) is the Bürkert Communicator. This software can be run under MS-Windows and it is available on Bürkert's website for free. The Bürkert Communicator allows convenient system configuration and parametrisation of all connected field devices. An accessory part, the bÜS stick serves as the interface between computer and process instruments (see "7.4. Ordering chart accessories" on page 8). The Communicator allows:

- Diagnostics
- Parametrization
- Registration and storage of process data
- Graphical monitoring of the process data
- To update firmware of the bÜS device connected
- Guided re-calibration

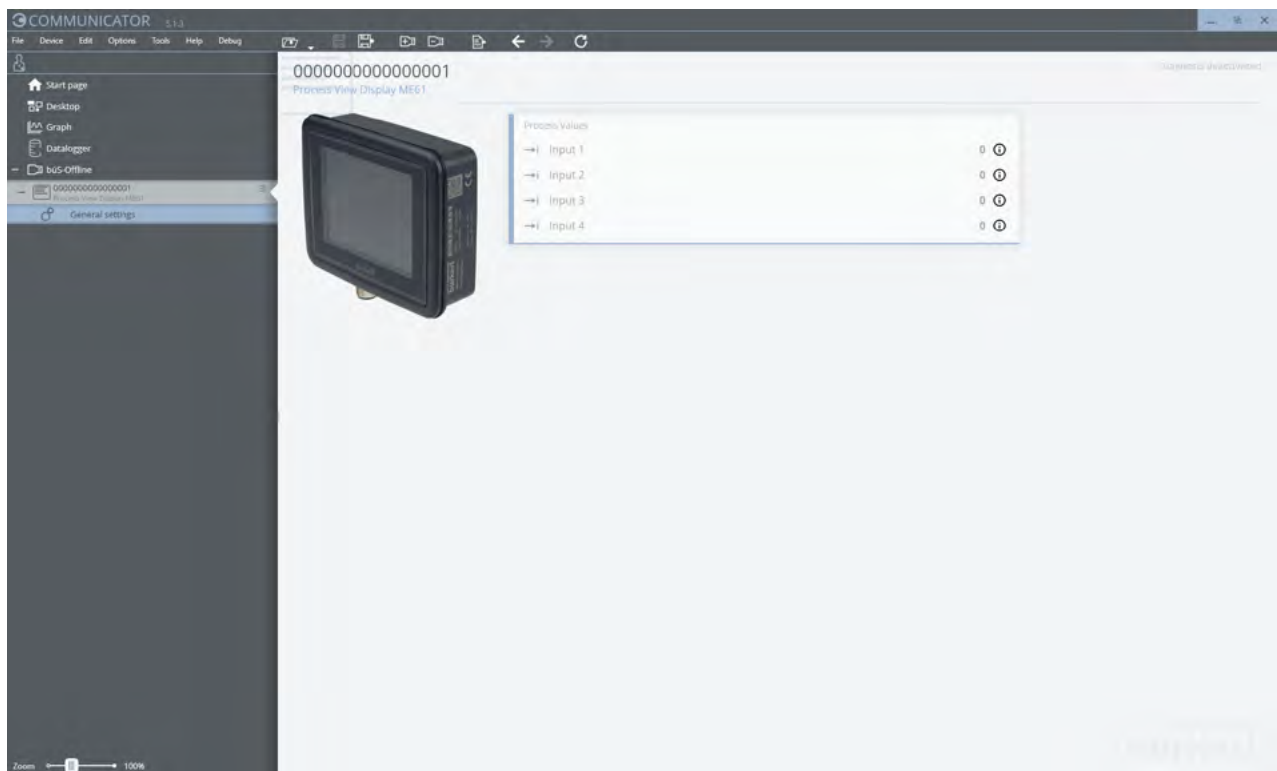

6. Networking and combination with other Bürkert products

Note:

- Lengths of stub lines should not be longer than 5 m.
- Signal integrity measurement is recommended for star cabling of more extensive networks.
- See also **cabling guide** ▶

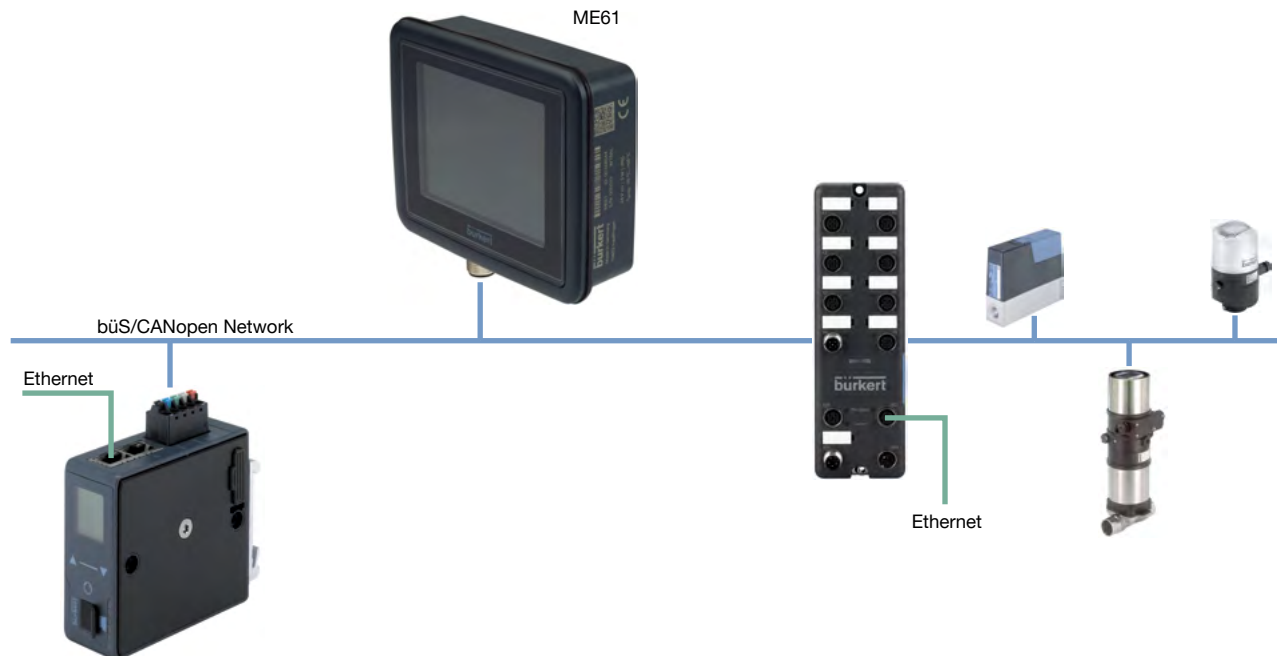

Short description of the illustrated example:

- Connection of 6 Bürkert devices via büS/CANopen network
- All büS devices can be reached via gateway over Ethernet.
- ME43 or ME63 Industrial Ethernet Gateways can also connect complex büS systems to higher-level Ethernet networks.
- A total of up to 126 büS/CANopen devices can be connected to one gateway.
- ME61 can be configured to display up to 4 arbitrary values of the büS devices in the network.
- Other ME61 can be connected to the büS network to display additional parameters.

7. Ordering information

7.1. Bürkert eShop – Easy ordering and quick delivery



Bürkert eShop – Easy ordering and fast delivery

You want to find your desired Bürkert product or spare part quickly and order directly? Our online shop is available for you 24/7. Sign up and enjoy all the benefits.

[Order online now](#)

7.2. Bürkert product filter



Bürkert product filter – Get quickly to the right product

You want to select products comfortably based on your technical requirements? Use the Bürkert product filter and find suitable articles for your application quickly and easily.

[Try out our product filter](#)





















7.3. Ordering chart

Note:

Please note that the ME61 gateway modules are not configured at the factory. However, they must be configured to enable their use in a system. The device description files for the required protocols must be generated with the communicator software before commissioning a system. You can find further details in the [Operating manual for ME61](#) ►.

Article	Article no.
Process view display ME61 (3.5")	368544 
Process Control Display ME61 (7")	368545 

7.4. Ordering chart accessories

Article	Article no.
Magnetic holder for ME61	394071 
büS cable extension, M12, 0.1 m	772492 
büS cable extension, M12, 0.2 m	772402 
büS cable extension, M12, 0.5 m	772403 
büS cable extension, M12, 1 m	772404 
büS cable extension, M12, 3 m	772405 
M12 socket, straight (A-coded) ^{1.)}	772416 
M12 plug, straight (A-coded) ^{1.)}	772417 
M12 socket, angled (A coded) ^{1.)}	772418 
M12 plug, angled (A-coded) ^{1.)}	772419 
Y distributor	772420 
Y distributor for connecting two separately powered segments of a büS network	772421 
Terminating resistor, 120 Ohm, M12 plug	772424 
Terminating resistor, 120 Ohm, M12 socket	772425 
Power supply unit Type 1573 for DIN rail, 100...240 V AC/24 V DC, 1.25 A, NEC Class 2 (UL 1310)	772438 
Power supply unit Type 1573 for DIN rail, 100...240 V AC/24 V DC, 1 A, NEC Class 2 (UL 1310)	772361 
Power supply unit Type 1573 for DIN rail, 100...240 V AC/24 V DC, 2 A, NEC Class 2 (UL 1310)	772362 
Power supply unit Type 1573 for DIN rail, 100...240 V AC/24 V DC, 3.8 A, NEC Class 2 (UL 1310)	772898 
Power supply unit Type 1573 for DIN rail, 100...240 V AC/24 V DC, 10 A	772698 
büS-Stick Set 1 (incl. cable (M12), stick with integrated terminating resistor, power supply and software)	772426 
büS-Stick Set 2 (incl. cable (M12)), stick with integrated terminating resistor	772551 
Software Bürkert Communicator	Link ►

1.) For space reasons, the individual M12 connectors may not be suitable for simultaneous use on the same side of a Y distributor. In this case, please use a commercially available moulded cable.

Bürkert – Close to You

For up-to-date addresses
please visit us at
www.burkert.com

DTS 1000463135 EN Version: C Status: RL (released | freigegeben | validé) printed: 07.04.2022

